

INSTRUCTION MANUAL

Mini-Fast Sub

cat. # MGU-303

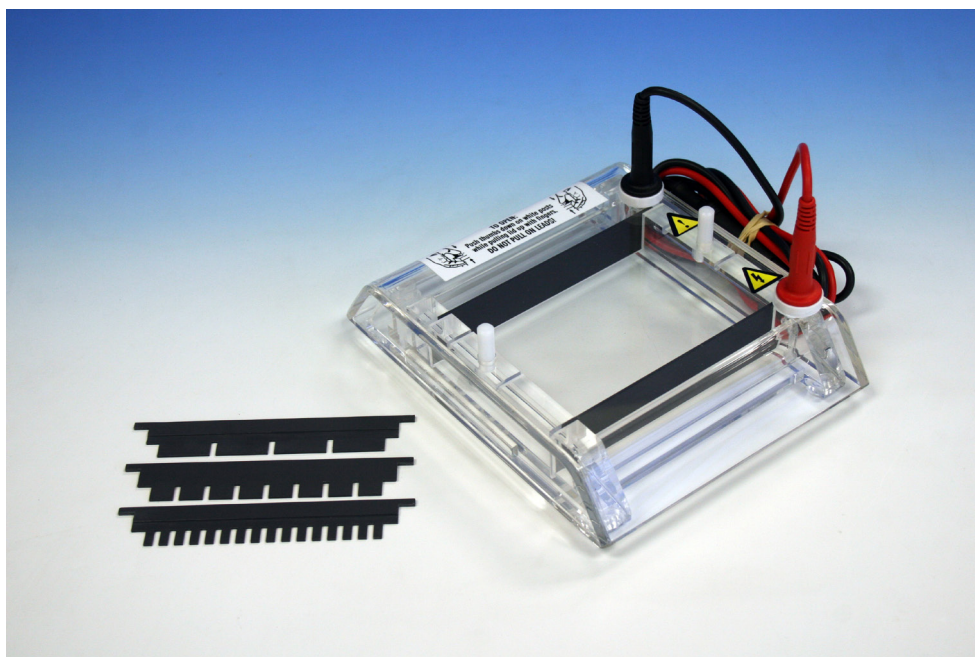

TABLE OF CONTENTS

	Page
Important User Information	3-4
Section 1 General Information	
1.1 Introduction	5
1.2 Specifications	5
1.3 Safety	5
Section 2 Description of parts	
2.1 Unpacking	6
2.2 Components/Assembly	6
Section 3 Instructions for Use	
3.1 Mini-Gel Unit Preparation and Gel Casting	7
3.2 Running the Gel	7
3.3 Removing the Gel	8
3.4 Maximum well/Comb volumes	8
Section 4 Running Conditions	
4.1 Recommended Power	9
4.2 Recommended Buffers	9
Section 5 Maintenance of Equipment	
5.1 Care and Handling	10
5.2 Maintenance	10
Section 6 Mini-Fast Sub and Accessories	11

IMPORTANT USER INFORMATION

This Instruction Manual will explain how to use this product safely and effectively. Please read and carefully follow the instruction manual in its entirety.



The triangle/exclamation mark symbol alerts the user of the product to important operational, maintenance, and/or warranty requirements.



The triangle/lighting bolt symbol alerts the user of the product to potentially hazardous electrical exposure.



Failure to adhere to the instructions could result in personal and/or laboratory hazards, as well as invalidate any warranty. Always turn off the DC power source prior to disconnecting power cords from the product. Disconnect power cords from the power source first, and then from the product. For maximum safety, always operate this system in an isolated, low traffic area, not accessible to unauthorized personnel. Never operate damaged or leaking equipment.

WARRANTY AND LIABILITY

This product was produced utilizing the highest practical standards of materials, workmanship, and design. C.B.S. Scientific warrants that the product has been tested and will meet or exceed published specifications. This warranty is valid only if the product has been operated and maintained according to the instructions provided.

C.B.S. Scientific warrants this product to be free from defects in materials and workmanship under normal service for one year from date of shipment. If the product proves defective during this period, C.B.S. Scientific will repair or replace it at our option, free of charge, if returned to us postage prepaid. This warranty does not cover: damage in transit, damage caused by carelessness, misuse or neglect, normal wear through frequent use, damage caused by solvent corrosion, damage caused by improper handling or user alteration, nor unsatisfactory performance as a result of conditions beyond our control. C.B.S. Scientific shall in no event be liable for incidental nor consequential damages, including without limitation, lost profits, loss of income, loss of business opportunities, loss of use and other related damages, however caused, nor any damage arising from the incorrect use of the product.

<p>FRANÇAIS INFORMATION IMPORTANTE À L'USAGE DES UTILISATEURS</p> <p>Le présent manuel d'utilisation explique la manière de se servir efficacement du produit en conditions de sécurité. Il est recommandé de soigneusement lire la totalité du manuel, avec ses consignes et ses instructions.</p> <p> Le triangle avec point d'exclamation est un symbole destiné à avertir l'utilisateur du produit de l'importance de certaines exigences relatives au fonctionnement, à l'entretien et/ou à la garantie.</p> <p> Le triangle avec flèche en zigzag est un symbole destiné à avertir l'utilisateur du produit de la possibilité d'exposition à des décharges avec danger de secousses électriques.</p> <p> Tout manquement à l'observation des consignes et des instructions peut exposer les personnes et les biens à des dommages corporels et/ou matériels et peut annuler toute garantie. Il faut toujours interrompre l'alimentation de courant continu avant de déconnecter les cordons d'alimentation du produit. Déconnecter d'abord les cordons d'alimentation branchés sur la source de tension (alimentation de secteur) puis ceux branchés sur le produit. Pour une sécurité maximum, il faut toujours faire fonctionner ce système dans un lieu isolé, peu fréquenté, où le personnel non autorisé n'a pas accès. Ne jamais faire fonctionner un matériel endommagé ou affecté par des fuites.</p> <p>GARANTIE ET RESPONSABILITÉ</p> <p>Le produit a été fabriqué conformément aux normes applicables les plus exigeantes en matière de matériaux, de main d'œuvre, de conception et d'ingénierie. C.B.S. Scientific garantit que le produit a subi des essais et que ses performances rempliront les conditions des spécifications publiées ou leur seront même supérieures. La présente garantie n'est valide que si le produit a fonctionné et a été entretenu conformément aux consignes et instructions fournies.</p> <p>C.B.S. Scientific garantit que le produit sera dépourvu de vices de matériaux et de main d'œuvre, en conditions de service normales, pendant un an à compter de la date d'expédition. Au cas où le produit s'avérerait défectueux pendant cette période de garantie, C.B.S. Scientific réparera ou remplacera le produit, à sa discrétion et gratuitement, si le produit lui est retourné port payé d'avance. La garantie ne couvre pas les dommages de transport; les dommages causés par l'imprudence, le manque de soins, l'abus ou la négligence; l'usure normale résultant d'une utilisation fréquente; les dommages causés par la corrosion des solvants; et les dommages causés par la manipulation inadéquate ou des changements apportés par l'utilisateur. La garantie ne couvre pas non plus les performances non satisfaisantes résultant de conditions hors du contrôle de C.B.S. Scientific. C.B.S. Scientific ne pourra en aucun cas être tenue responsable de dommages indirects, y compris, de manière non limitative, la perte de bénéfices, le manque à gagner, la perte d'occasions d'affaires, l'impossibilité d'usage ou tous autres dommages associés, quelle qu'en soit la cause, ni de dommages résultant de l'usage incorrect du produit.</p>	<p>ESPAÑOL INFORMACIÓN IMPORTANTE PARA EL USUARIO</p> <p>El presente instructivo explica la manera de usar este producto en forma segura y efectiva. Sírvase leerlo en su totalidad y seguir detenidamente las indicaciones que contiene.</p> <p> El símbolo del triángulo con exclamación llama la atención del usuario a requisitos importantes para el uso y mantenimiento del producto, así como para la validez de la garantía.</p> <p> El símbolo del triángulo con rayo llama la atención del usuario a la posibilidad de riesgos eléctricos.</p> <p> El incumplimiento de las instrucciones aquí señaladas podría dar lugar a riesgos a la persona, al laboratorio o a ambos y podría anular toda garantía. Siempre apague la fuente de corriente continua antes de desenchufar los cables eléctricos del producto. Primero desconecte los cables de la fuente de energía y después del producto. Para mayor seguridad, siempre use este sistema en un área aislada, de poco movimiento de personas e inaccesible a personal no autorizado. Jamás use equipo que presenta algún daño o fuga.</p> <p>GARANTÍA Y RESPONSABILIDAD</p> <p>Este producto fue fabricado de acuerdo con las normas más estrictas que sean factibles en cuanto a materiales, mano de obra y diseño. C.B.S. Scientific garantiza que se sometió el producto a pruebas y que cumplirá o excederá las especificaciones publicadas. Esta garantía será válida únicamente si se usa y se da servicio de mantenimiento al producto de acuerdo con las instrucciones señaladas.</p> <p>C.B.S. Scientific garantiza que este producto se encontrará libre de defectos de materiales y mano de obra por un período de servicio normal de un año a partir de la fecha de embarque. Si el producto resulta defectuoso durante este período, C.B.S. Scientific lo reparará o lo repondrá, a criterio de C.B.S., libre de cargos, si se devuelve el producto a C.B.S. porte pagado. Esta garantía no cubre daños sufridos en tránsito, daños provocados por descuido, mal uso o negligencia, desgaste normal como consecuencia del uso excesivo, daños atribuibles a corrosión provocada por solventes, daños causados por el uso indebido o alteraciones realizadas por el usuario ni rendimiento insatisfactorio atribuible a circunstancias fuera del control de C.B.S. Scientific. C.B.S. Scientific en ningún caso asumirá responsabilidad por daños incidentales o subsecuentes, incluyendo, en forma no limitativa, la pérdida de utilidades, de ingresos, de oportunidades comerciales o del uso del producto y otros daños afines, fuere cual fuere su origen, ni por daños derivados del uso incorrecto del producto.</p>
<p>DEUTSCH WICHTIGE INFORMATION FÜR DEN BENUTZER</p> <p>Diese Bedienungsanleitung beschreibt wie man dieses Produkt sicher und wirksam benutzt. Bitte lesen und befolgen Sie alle Anweisungen in dieser Anleitung.</p> <p> Das Dreieck mit Ausrufezeichen weist den Benutzer des Produktes darauf hin, daß wichtige Bedienungs-, Wartungs- und/oder Garantievorschriften zu beachten sind.</p> <p> Das Dreieck mit Zickzackblitz warnt den Benutzer des Produktes vor möglichen Gefahren durch elektrische Spannungen.</p> <p> Nichtbeachtung dieser Anweisungen kann zu persönlichen und/oder labortechnischen Schäden führen und gleichzeitig alle Garantien als nichtig erklären. Die DC Stromzufuhr muß immer, vor dem Entfernen der Stromkabel vom Produkt, abgeschaltet werden. Die Stromzufuhrkabel müssen zuerst von der Steckdose und erst dann vom Produkt entfernt werden. Um höchste Sicherheit zu gewährleisten sollte dieses System in einem abgesonderten und besonders ruhigen Bereich eingesetzt werden und vor Unbefugten sicher sein.</p> <p>GARANTIE UND HAFTUNG</p> <p>Dieses Produkt wurde unter Anwendung von Produkten mit höchster Qualität und aus Materialien mit bester Verarbeitung und modernstem Design hergestellt. C.B.S. Scientific garantiert, daß das Produkt getestet wurde und alle publizierten Spezifikationen übertrifft. Diese Garantie ist jedoch nur gültig, wenn das Produkt nach der beigefügten Bedienungsanleitung bedient und gewartet wurde.</p> <p>C.B.S. Scientific garantiert, daß dieses Produkt bei normaler Bedienung aus fehlerfreiem Material besteht und fehlerfrei in der Ausführung ist. Diese Garantie gilt für ein Jahr ab Lieferdatum. Sollte das Produkt in diesem Zeitraum fehlerhaft werden, bietet C.B.S. Scientific eine kostenlose Reparatur bzw. kostenlosen Ersatz, einschließlich freiem Rückporto. Diese Garantie schließt folgendes aus: Transportschaden, Schaden durch Nachlässigkeit, Mißbrauch oder Vernachlässigung, normale Abnutzung durch regelmäßigen Gebrauch, Schaden durch Säureangriff, Schaden durch falsche Handhabung, Veränderung des Produktes durch den Benutzer, oder unzureichende Leistungen die sich nicht im Verantwortungsbereich von C.B.S. Scientific befinden. C.B.S. Scientific kommt unter keinen Umständen für folgende Schäden auf: Sachschadensverlust, Einkommensverlust, Verlust von Geschäftsmöglichkeiten, Verlust der Anwendung und andere damit verbundene Schäden die auf irgend eine Art und Weise entstanden sind, oder Schäden die aus falscher Anwendung des Produktes entstanden sind.</p>	<p>ITALIANO INFORMAZIONI IMPORTANTI PER L'UTENTE</p> <p>Questo manuale spiega come utilizzare questo prodotto in maniera sicura ed efficiente. Si preghi di leggere e seguire con cautela le istruzioni di ogni parte di questo manuale.</p> <p> Il triangolo contenete il simbolo di un punto esclamativo avverte l'utente di importanti requisiti relativi al funzionamento, manutenzione e/o garanzia del prodotto.</p> <p> Il triangolo contenete il simbolo di un lampo avverte l'utente del prodotto della possibilità di pericoli dovuti a corrente elettrica.</p> <p> La mancata osservanza delle istruzioni può essere causa di pericolo alla propria persona ed al laboratorio, oltre a poter annullare la garanzia. Prima di distaccare il cordone d'alimentazione dal prodotto, spegnere sempre la sorgente di corrente continua. Distaccare i cordoni d'alimentazione prima dal lato della sorgente di tensione e poi dal lato del prodotto. Per maggior sicurezza, mettere sempre in funzione il prodotto in un'area isolata con poco traffico che non sia accessibile al personale non autorizzato. Non mettere mai in funzione un'apparecchiatura che sia danneggiata o abbia perdite.</p> <p>GARANZIA E RESPONSABILITÀ</p> <p>Questo prodotto è stato fabbricato seguendo gli standard più elevati per i materiali, la manodopera e la progettazione. La C.B.S. Scientific garantisce il prodotto è stato sottoposto a prova e raggiunge o supera i valori pubblicati per i dati tecnici. Questa garanzia è valida solo se il prodotto è messo in esercizio e soggetto a manutenzione secondo le istruzioni fornite.</p> <p>La C.B.S. Scientific garantisce che questo prodotto è libero di difetti di materiali e manodopera, in normali condizioni d'esercizio, per la durata di un anno dalla data di spedizione. Se, in questo periodo, il prodotto si dimostrerà difettoso, la C.B.S. Scientific, a suo giudizio, lo riparerà o sostituirà. Questa garanzia non copre danni in transito, danni causati da negligenza, uso improprio, trascuratezza, normale consumo derivante da uso frequente, o danni causati da solventi corrosivi, danni causati da maltrattamento o da modifiche apportate dall'utente e non copre prestazioni insoddisfacenti che siano il risultato di condizioni al di fuori del controllo del fabbricante. La C.B.S. Scientific non sarà in ogni caso responsabile per danni incidentali o consequenziali, incluso, senza limitazioni, perdite di profitto, perdita di entrate, perdita di opportunità d'affari e altri danni relativi, comunque causati, e per danni risultanti da uso incorrecto del prodotto.</p>

SECTION 1 General Information

1.1 Introduction

The Mini-Fast Sub, cat. #MGU-303, features a simple and safe design. Gel casting is easily accomplished by inserting the precision fit dams and comb into the grooves provided in the body of the unit. The gel bed dimensions are 8cm (l) x 10cm (w). This uniplanar design has a buffer chamber only slightly longer than the gel itself, minimizing the amount of buffer required.

1.2 Specifications

Constructions

Buffer chamber, lid	Acrylic, UVT
Electrodes	Platinum wire .012" diameter
Power cords	FR Urethane, rated 7500V, 200mA, 65° C
Casting dams	PVC
Combs	PVC
Safety Certification	EN61010-1-1993 (IEC1010-1)

	MGU-303
Shipping weight	3lbs
Overall Size (l)x(w)x(h)	17cm x 14cm x 8cm
Gel Size	7.5cm x 10cm
Recommended buffer volume mls	50ml
Distance between electrodes	9.5cm
Voltage limit	100VDC

1.2 Safety



Power to the MGU-303 unit is to be supplied by an external DC voltage power supply that must be ground isolated so that the DC voltage output floats with respect to ground. For any power supply used, the maximum specified operating parameters for the units are:

Maximum Limits

100VDC voltage
50 watts power
50 mA current
55°C ambient temperature



Current to the unit, provided from the external power supply, must enter the unit through the lid assembly, providing a safety interlock to the user. Current to the unit is broken when the lid is removed. **Do not attempt to use the unit without the safety lid. Always turn the power supply off before removing the lid, or when working with the unit in any way. Follow safety precautions specified by the power supply manufacturer.**

SECTION 2 Description of Parts

2.1 Unpacking

Please verify that your MGU-303 unit comes complete with the following components:

- Mini-Horizontal electrophoresis unit
- Gel Casting dams (2)
- Safety cover with attached DC power cords
- Combs, 1 of each 4 well, 8 well, and 16 well in 1mm or 2mm thickness

2.2 Components/Assembly

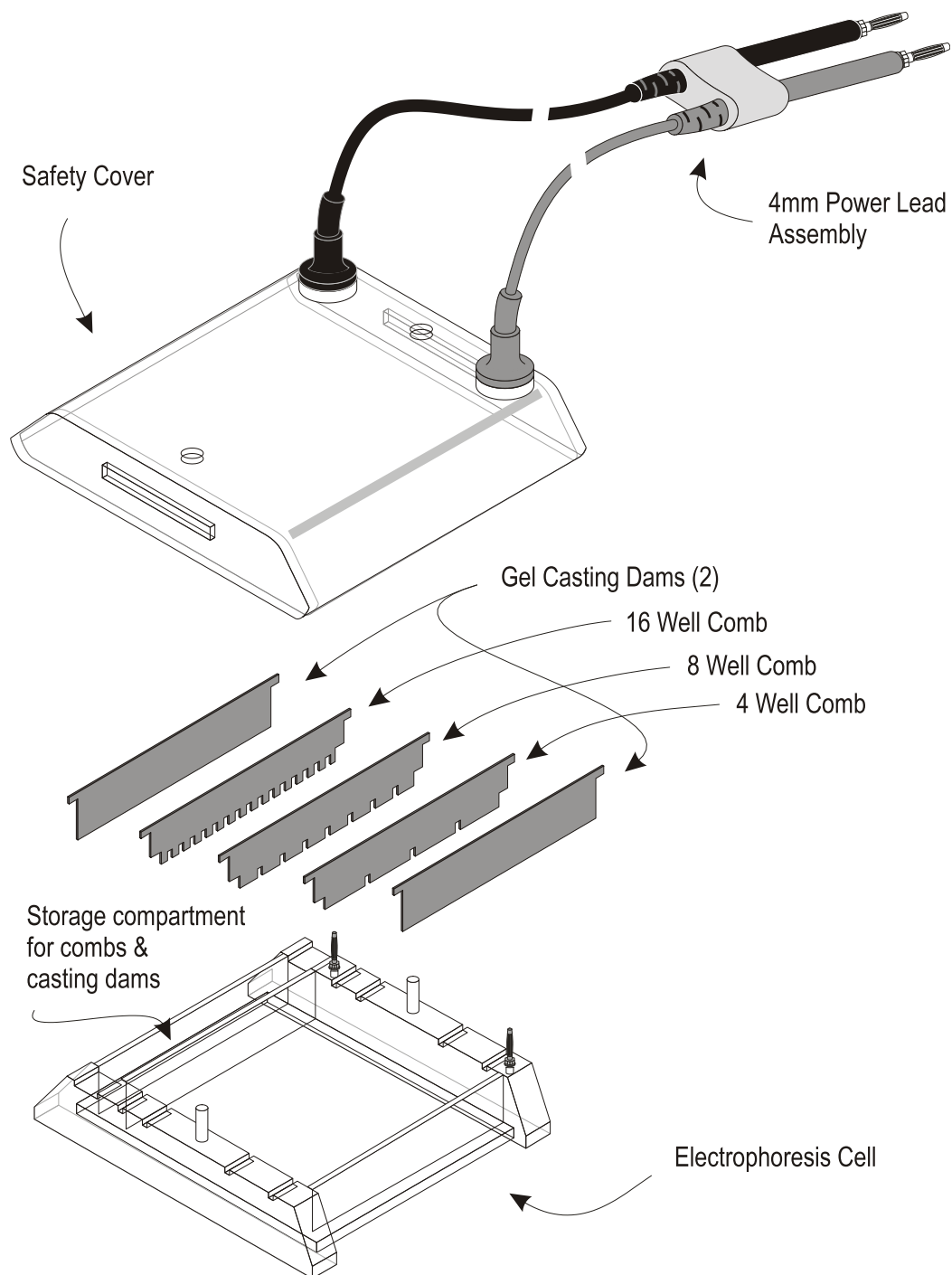

SECTION 3

Instructions for Use



3.1 Mini-Gel Unit Preparation and Gel Casting

Place Mini-Gel unit on a level work surface in an authorized work area. Insert the gray dams directly into the pre-machined slots located at each end of the unit within the electrophoresis chamber. Ensure the fit for each dam is snug. The addition of agarose plugs or any other sealing method is not required; the precision fit dams will ensure a leak-free agarose gel cast. Insert the comb of choice.

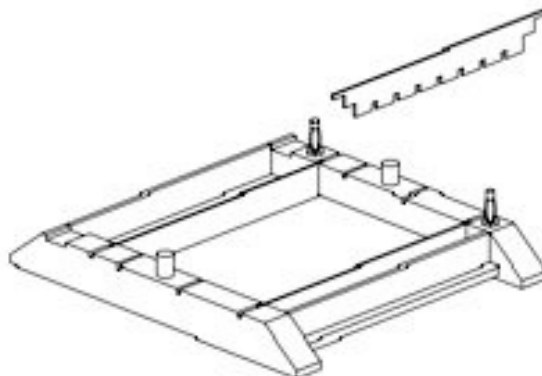

Add exactly 40mls of molten agarose directly into the chamber. Allow the gel to cool, uncovered; slab will become opaque when properly set. Gently pull out the gray dams used to form the sides of the agarose gel slab.

3.2 Running the Gel

1. Add buffer: minimum volume is 40mls; maximum volume is 60mls. Add enough buffer to fill both reservoirs and overflow the surface of the gel to a depth of 2-3mm. Gently, remove gel comb; flush out any bubbles in wells with a pipette. Flush out any air bubbles in the wells. Load the samples into sample wells. Place the safety cover on the unit. **NOTE: DO NOT FORGET TO LOAD DNA SIZE STANDARD.**



2. Connect the leads to the power supply, matching the color-coded red to red and black to black. **See Section 4.1 for recommended power conditions.**

3. Begin separation by electrophoresis.



3.3 Removing the gel

Turn the power supply off and disconnect the leads from the power supply. Remove the safety cover from the Mini-Gel unit by placing thumbs on white posts next to red & black connectors, then pushing down while pulling up with fingers under lid. **DO NOT pull on power cords.**

Gently lift the gel from the unit. **Always wear gloves, eye protection and protective clothing** if buffer and/or gel contain Ethidium Bromide. Ethidium Bromide is a powerful mutagen, gloves, eye protection and protective clothing should always be worn when handling the gel or buffer solutions. See Material Data Safety Sheets.

View separated fragments under UV light, using proper protection for eyes and skin (see manufacturer's instructions).

3.4 Maximum Well/Comb Volumes

NOTE: To calculate sample well volume expressed in millimeters (mm) of height, divide maximum volume by tooth depth.

# of wells	Tooth width (mm)	Spacing Between teeth (mm)	Overall length (mm)	Tooth depth (mm)	1.0mm thickness volume per tooth microliters (ul)	2.0mm thickness volume per tooth microliters (ul)
4	20.2	2.35	88.26	5.37	108.47	216.94
8	8.88	2.28	88.26	5.37	47.69	95.38
16	3.27	2.16	88.26	5.37	17.56	35.12

SECTION 4

Running Conditions

4.1 Recommended Power



The recommended power conditions for optimal resolution are 50VDC / 25mA ≤ 60 minutes. Constant power is not a necessity, but it produces uniform heat throughout the run. Be sure the polarity is correct i.e. that the DNA is loaded near the cathode (black electrode) to run toward the anode (red terminal).

Agarose gels may be stored for several days at 4°C wrapped in plastic wrap. Seakem Agarose (FMC) is used (normally) for preparative and analytical gels. Other types of agarose can be used for special purposes.

4.2 Recommended Buffers

TBE	5X - 54 gm Tris base	0.5X - 0.045M Tris-borate
(Tris-borate)	27.5 gm boric acid	0.001M EDTA
	20 ml 0.5M EDTA (pH 8.0)	

10X - Loading Buffer (DNA)*

0.25% Bromophenol blue

0.25% Xylene cyanol

20 % Ficoll Type 400

0.1M EDTA, pH 8.0



Ethidium Bromide Staining

One can add to the buffer only, the agarose gel solution only (after the solution has been made molten and the temperature has dropped to 55°C), or can be added after the electrophoresis run and the gel stained separately. Use at a final concentration of 0.1µg/ml from a 1mg/ml stock solution. Ethidium bromide is a Mutagen. ALWAYS wear gloves. Dispose of solutions in accordance with the safety regulations of your institution.

4.3 References

1. Hames, B.D., Rickwood, D. (ed.) (1990). *Gel Electrophoresis of Nucleic Acids. A Practical Approach*. 2nd edn. IRL Press, Oxford. Ch. 2.
2. Sambrook, J., Fritsch, E.F., Maniatis, T. (1989). *Molecular Cloning. A Laboratory Manual*. 2nd edn. Cold Spring Harbor Laboratory Press, Cold Spring Harbor, New York. Ch 6.
3. Ausubel, F.M., Brent, R., Kingston, R.E., Moore, D.D., Seidman, J.G., Smith, J.A., Struhl, K. (ed) (1993). *Current Protocols in Molecular Biology*. Vol. 1, Greene Publishing Associates, Inc. and John Wiley & Sons, Inc., Ch. 2.

SECTION 5

Maintenance of Equipment

5.1 Care and Handling



The plastic components of the Mini-Horizontal units are fabricated from acrylic and polycarbonate. Electrodes and connectors are made from pure platinum, stainless steel, and chrome plated brass. As with any laboratory instrument, adequate care ensures consistent and reliable performance.

After each use, rinse buffer chamber, gel tray and combs with de-ionized water. Wipe dry with a soft cloth or paper towel, or allow to air dry. Whenever necessary, all components may be washed gently with water and a non-abrasive detergent, and rinsed and dried as above. *Never* use abrasive cleaners, glass cleaning sprays or scouring pads to clean the components, as these will damage the unit and components.

Additional precautions:

- Do not autoclave or dry-heat sterilize the apparatus or components.
- Do not expose the apparatus or components to phenol, acetone, benzene, halogenated hydrocarbon solvents or undiluted alcohol's.
- Avoid prolonged exposure of the apparatus or components to UV light.
- Do NOT treat with diethylpyrocarbonate (DEPC)-treated water for extended periods at 37°C. A brief rinse with DEPC-water is sufficient after a thorough wash.

5.2 Maintenance



The following inspection and maintenance procedures will help maintain the safety and reliable performance of the Mini-Horizontal systems. Replacement parts can be ordered by calling 1 858-755-4959 or by contacting your local distributor.

- Banana plugs and power cords should be inspected regularly. If the banana plugs become loose or do not feel friction tight replace the plugs or power cords.
- Should power cord assemblies (connectors, wire or shrouds) show any signs of wear or damage (e.g. cracks, nicks, abrasions, or melted insulation), replace them immediately.
- The platinum wire is secured to the banana jack by compression between a stainless washer and the jack nut. The nut/washer interface should be tight and free of corrosion.

SECTION 6 Ordering Information

Cat. #	Item
MGU-303	Mini-Fast Sub - CE , Includes interlocking safety cover, 2 gel casting dams and choice of 2 combs
MGU-COMB1	Comb , 1.0mm x 4 wells
MGU-COMB2	Comb , 1.0mm x 8 wells
MGU-COMB3	Comb , 1.0mm x 16 wells
MGU-COMB4	Comb , 2.0mm x 4 wells
MGU-COMB5	Comb , 2.0mm x 8 wells
MGU-COMB6	Comb , 2.0mm x 16 wells
MCD-300	Additional Gel Casting Dams (set of 2)
EPS-300-II	Mini Power Supply , with timer, CV or CC, 10-300V, 110V/60Hz, current range:4-500mA, 90 watts
EPS-300-IIV	Mini Power Supply , with timer, CV or CC, 10-300V, 220V/50Hz, current range:4-500mA, 90 watts