

# INSTRUCTION MANUAL

## Horizontal Midi Gel Systems

**MGU-402T**

**MGU-502T**

**MGU-602T**



# TABLE OF CONTENTS

	Page
<b>Important User Information</b>	3-4
<b>Section 1    General Information</b>	
1.1    Introduction	5
1.2    Specifications	5
1.3    Safety	5
<b>Section 2    Description of parts</b>	
2.1    Unpacking	6
2.2    Components/Assembly	6
<b>Section 3    Instructions for Use</b>	
3.1    Midi-Gel Unit Preparation and Gel Casting	7-8
3.2    Running the Gel	8
3.3    Removing the Gel	9
3.4    Maximum Well/Comb volumes	10
<b>Section 4    Running Conditions</b>	
4.1    Recommended Power	10
4.2    Recommended Buffers	10-11
<b>Section 5    Maintenance of Equipment</b>	
5.1    Care and Handling	11
5.2    Maintenance	11
<b>Section 6    Equipment and Accessories</b>	12-13

## IMPORTANT USER INFORMATION

This Instruction Manual will explain how to use this product safely and effectively. Please read and carefully follow the instruction manual in its entirety.



The triangle/exclamation mark symbol alerts the user of the product to important operational, maintenance, and/or warranty requirements.



The triangle/lightning bolt symbol alerts the user of the product to potentially hazardous electrical exposure.















Failure to adhere to the instructions could result in personal and/or laboratory hazards, as well as invalidate any warranty. Always turn off the DC power source prior to disconnecting power cords from the product. Disconnect power cords from the power source first, and then from the product. For maximum safety, always operate this system in an isolated, low traffic area, not accessible to unauthorized personnel. Never operate damaged or leaking equipment.

## WARRANTY AND LIABILITY

This product was produced utilizing the highest practical standards of materials, workmanship, and design. C.B.S. Scientific warrants that the product has been tested and will meet or exceed published specifications. This warranty is valid only if the product has been operated and maintained according to the instructions provided.

C.B.S. Scientific warrants this product to be free from defects in materials and workmanship under normal service for one year from date of shipment. If the product proves defective during this period, C.B.S. Scientific will repair or replace it at our option, free of charge, if returned to us postage prepaid. This warranty does not cover: damage in transit, damage caused by carelessness, misuse or neglect, normal wear through frequent use, damage caused by solvent corrosion, damage caused by improper handling or user alteration, nor unsatisfactory performance as a result of conditions beyond our control. C.B.S. Scientific shall in no event be liable for incidental nor consequential damages, including without limitation, lost profits, loss of income, loss of business opportunities, loss of use and other related damages, however caused, nor any damage arising from the incorrect use of the product.

<p><b>FRANÇAIS INFORMATION IMPORTANTE À L'USAGE DES UTILISATEURS</b></p> <p>Le présent manuel d'utilisation explique la manière de se servir efficacement du produit en conditions de sécurité. Il est recommandé de soigneusement lire la totalité du manuel, avec ses consignes et ses instructions.</p> <p> Le triangle avec point d'exclamation est un symbole destiné à avertir l'utilisateur du produit de l'importance de certaines exigences relatives au fonctionnement, à l'entretien et/ou à la garantie.</p> <p> Le triangle avec flèche en zigzag est un symbole destiné à avertir l'utilisateur du produit de la possibilité d'exposition à des décharges avec danger de secousses électriques.</p> <p> Tout manquement à l'observation des consignes et des instructions peut exposer les personnes et les biens à des dommages corporels et/ou matériels et peut annuler toute garantie. Il faut toujours interrompre l'alimentation de courant continu avant de déconnecter les cordons d'alimentation du produit. Déconnecter d'abord les cordons d'alimentation branchés sur la source de tension (alimentation de secteur) puis ceux branchés sur le produit. Pour une sécurité maximum, il faut toujours faire fonctionner ce système dans un lieu isolé, peu fréquenté, où le personnel non autorisé n'a pas accès. Ne jamais faire fonctionner un matériel endommagé ou affecté par des fuites.</p> <p><b>GARANTIE ET RESPONSABILITÉ</b></p> <p>Le produit a été fabriqué conformément aux normes applicables les plus exigeantes en matière de matériaux, de main d'œuvre, de conception et d'ingénierie. C.B.S. Scientific garantit que le produit a subi des essais et que ses performances rempliront les conditions des spécifications publiées ou leur seront même supérieures. La présente garantie n'est valide que si le produit a fonctionné et a été entretenu conformément aux consignes et instructions fournies.</p> <p>C.B.S. Scientific garantit que le produit sera dépourvu de vices de matériaux et de main d'œuvre, en conditions de service normales, pendant un an à compter de la date d'expédition. Au cas où le produit s'avérerait défectueux pendant cette période de garantie, C.B.S. Scientific réparera ou remplacera le produit, à sa discrétion et gratuitement, si le produit lui est retourné port payé d'avance. La garantie ne couvre pas les dommages de transport; les dommages causés par l'imprudence, le manque de soins, l'abus ou la négligence; l'usure normale résultant d'une utilisation fréquente; les dommages causés par la corrosion des solvants; et les dommages causés par la manipulation inadéquate ou des changements apportés par l'utilisateur. La garantie ne couvre pas non plus les performances non satisfaisantes résultant de conditions hors du contrôle de C.B.S. Scientific. C.B.S. Scientific ne pourra en aucun cas être tenue responsable de dommages indirects, y compris, de manière non limitative, la perte de bénéfices, le manque à gagner, la perte d'occasions d'affaires, l'impossibilité d'usage ou tous autres dommages associés, quelle qu'en soit la cause, ni de dommages résultant de l'usage incorrect du produit.</p>	<p><b>ESPAÑOL INFORMACIÓN IMPORTANTE PARA EL USUARIO</b></p> <p>El presente instructivo explica la manera de usar este producto en forma segura y efectiva. Sirvase leerlo en su totalidad y seguir detenidamente las indicaciones que contiene.</p> <p> El símbolo del triángulo con exclamación llama la atención del usuario a requisitos importantes para el uso y mantenimiento del producto, así como para la validez de la garantía.</p> <p> El símbolo del triángulo con rayo llama la atención del usuario a la posibilidad de riesgos eléctricos.</p> <p> El incumplimiento de las instrucciones aquí señaladas podría dar lugar a riesgos a la persona, al laboratorio o a ambos y podría anular toda garantía. Siempre apague la fuente de corriente continua antes de desenchufar los cables eléctricos del producto. Primero desconecte los cables de la fuente de energía y después del producto. Para mayor seguridad, siempre use este sistema en un área aislada, de poco movimiento de personas e inaccesible a personal no autorizado. Jamás use equipo que presenta algún daño o fuga.</p> <p><b>GARANTÍA Y RESPONSABILIDAD</b></p> <p>Este producto fue fabricado de acuerdo con las normas más estrictas que sean factibles en cuanto a materiales, mano de obra y diseño. C.B.S. Scientific garantiza que se sometió el producto a pruebas y que cumplirá o excederá las especificaciones publicadas. Esta garantía será válida únicamente si se usa y se da servicio de mantenimiento al producto de acuerdo con las instrucciones señaladas.</p> <p>C.B.S. Scientific garantiza que este producto se encontrará libre de defectos de materiales y mano de obra por un periodo de servicio normal de un año a partir de la fecha de embarque. Si el producto resulta defectuoso durante este periodo, C.B.S. Scientific lo reparará o lo repondrá, a criterio de C.B.S., libre de cargos, si se devuelve el producto a C.B.S. porte pagado. Esta garantía no cubre daños sufridos en tránsito, daños provocados por descuido, mal uso o negligencia, desgaste normal como consecuencia del uso excesivo, daños atribuibles a corrosión provocada por solventes, daños causados por el uso indebido o alteraciones realizadas por el usuario ni rendimiento insatisfactorio atribuible a circunstancias fuera del control de C.B.S. Scientific. C.B.S. Scientific en ningún caso asumirá responsabilidad por daños incidentales o subsecuentes, incluyendo, en forma no limitativa, la pérdida de utilidades, de ingresos, de oportunidades comerciales o del uso del producto y otros daños ajenos, fuere cual fuere su origen, ni por daños derivados del uso incorrecto del producto.</p>
<p><b>DEUTSCH WICHTIGE INFORMATION FÜR DEN BENUTZER</b></p> <p>Diese Bedienungsanleitung beschreibt wie man dieses Produkt sicher und wirksam benutzt. Bitte lesen und befolgen Sie alle Anweisungen in dieser Anleitung.</p> <p> Das Dreieck mit Ausrufezeichen weist den Benutzer des Produktes darauf hin, daß wichtige Bedienungs-, Wartungs- und/oder Garantievorschriften zu beachten sind.</p> <p> Das Dreieck mit Zickzackblitz warnt den Benutzer des Produktes vor möglichen Gefahren durch elektrische Spannungen.</p> <p> Nichtbeachtung dieser Anweisungen kann zu persönlichen und/oder labortechnischen Schäden führen und gleichzeitig alle Garantien als nichtig erklären. Die DC Stromzufuhr muß immer, vor dem Entfernen der Stromkabel vom Produkt, abgeschaltet werden. Die Stromzufuhrkabel müssen zuerst von der Steckdose und erst dann vom Produkt entfernt werden. Um höchste Sicherheit zu gewährleisten sollte dieses System in einem abgesonderten und besonders ruhigen Bereich eingesetzt werden und vor Unbefugten sicher sein.</p> <p><b>GARANTIE UND HAFTUNG</b></p> <p>Dieses Produkt wurde unter Anwendung von Produkten mit höchster Qualität und aus Materialien mit bester Verarbeitung und modernstem Design hergestellt. C.B.S. Scientific garantiert, daß das Produkt getestet wurde und alle publizierten Spezifikationen übertrifft. Diese Garantie ist jedoch nur gültig, wenn das Produkt nach der beigefügten Bedienungsanleitung bedient und gewartet wurde.</p> <p>C.B.S. Scientific garantiert, daß dieses Produkt bei normaler Bedienung aus fehlerfreiem Material besteht und fehlerfrei in der Ausführung ist. Diese Garantie gilt für ein Jahr ab Lieferdatum. Sollte das Produkt in diesem Zeitraum fehlerhaft werden, bietet C.B.S. Scientific eine kostenlose Reparatur bzw. kostenlosen Ersatz, einschließlich freiem Rückporto. Diese Garantie schließt folgendes aus: Transportschaden, Schaden durch Nachlässigkeit, Mißbrauch oder Vernachlässigung, normale Abnutzung durch regelmäßigen Gebrauch, Schaden durch Säureangriff, Schaden durch falsche Handhabung, Veränderung des Produktes durch den Benutzer, oder unzureichende Leistungen die sich nicht im Verantwortungsbereich von C.B.S. Scientific befinden. C.B.S. Scientific kommt unter keinen Umständen für folgende Schäden auf: Sachschadensverlust, Einkommensverlust, Verlust von Geschäftsmöglichkeiten, Verlust der Anwendung und andere damit verbundene Schäden die auf irgend eine Art und Weise entstanden sind, oder Schäden die aus falscher Anwendung des Produktes entstanden sind.</p>	<p><b>ITALIANO INFORMAZIONI IMPORTANTI PER L'UTENTE</b></p> <p>Questo manuale spiega come utilizzare questo prodotto in maniera sicura ed efficiente. Si preghi di leggere e seguire con cautela le istruzioni di ogni parte di questo manuale.</p> <p> Il triangolo contenente il simbolo di un punto esclamativo avverte l'utente di importanti requisiti relativi al funzionamento, manutenzione e/o garanzia del prodotto.</p> <p> Il triangolo contenente il simbolo di un lampo avverte l'utente del prodotto della possibilità di pericoli dovuti a corrente elettrica.</p> <p> La mancata osservanza delle istruzioni può essere causa di pericolo alla propria persona ed al laboratorio, oltre a poter annullare la garanzia. Prima di distaccare il cordone d'alimentazione dal prodotto, spegnere sempre la sorgente di corrente continua. Distaccare i cordoni d'alimentazione prima dal lato della sorgente di tensione e poi dal lato del prodotto. Per maggior sicurezza, mettere sempre in funzione il prodotto in un'area isolata con poco traffico che non sia accessibile al personale non autorizzato. Non mettere mai in funzione un'apparecchiatura che sia danneggiata o abbia perdite.</p> <p><b>GARANZIA E RESPONSABILITÀ</b></p> <p>Questo prodotto è stato fabbricato seguendo gli standard più elevati per i materiali, la manodopera e la progettazione. La C.B.S. Scientific garantisce il prodotto è stato sottoposto a prova e raggiunge o supera i valori pubblicati per i dati tecnici. Questa garanzia è valida solo se il prodotto è messo in esercizio e soggetto a manutenzione secondo le istruzioni fornite.</p> <p>La C.B.S. Scientific garantisce che questo prodotto è libero di difetti di materiali e manodopera, in normali condizioni d'esercizio, per la durata di un anno dalla data di spedizione. Se, in questo periodo, il prodotto si dimostrerà difettoso, la C.B.S. Scientific, a suo giudizio, lo riparerà o sostituirà. Questa garanzia non copre danni in transito, danni causati da negligenza, uso improprio, trascuratezza, normale consumo derivante da uso frequente, o danni causati da solventi corrosivi, danni causati da maltrattamento o da modifiche apportate dall'utente e non copre prestazioni insoddisfacenti che siano il risultato di condizioni al di fuori del controllo del fabbricante. La C.B.S. Scientific non sarà in ogni caso responsabile per danni incidentali o consequenziali, incluso, senza limitazioni, perdite di profitto, perdita di entrate, perdita di opportunità d'affari e altri danni relativi, comunque causati, e per danni risultanti da uso incorretto del prodotto.</p>



## SECTION 1

### General Information

#### 1.1 Introduction

The mid-range Horizontal Midi-Gel units, MGU-402T (11 x 11cm), MGU-502T (10 x 14cm) and MGU-602T (14 x 14cm) effectively allow rapid separation and identification of various fragments from DNA, RNA, PCR™ products and synthetic oligonucleotides. When used in combination with two or more sample combs, designed for multi-channel pipette loading, multiple screening of large sample numbers can be facilitated easily. The unique tapered baffle system allows immediate gel casting directly onto removable trays without having to seal with agarose plugs or tape. The extensive variety of comb formats and material types ensure a fast and easy method of identifying critically important samples while using minimal quantities of expensive agarose.

#### 1.2 Specifications

##### Constructions:

Buffer chamber	Acrylic
Safety Cover	Acrylic
Electrodes	Platinum wire .012" diameter
Power cords	FR Urethane rated 7500VDC, 200mA, 65°C
Tapered baffles	Acrylic
Combs	Polycarbonate or Teflon
Adjustable comb backing	Acrylic
UVT Gel Tray	UV transparent acrylic
Safety Certification	EN61010-1-1993 (IEC1010-1)

	MGU-402T	MGU-502T	MGU-602T
Shipping weight	4lb.	6lb.	7lb.
Overall Size (l)x(w)x(h) cm	22.5 x 13 x 14	21.5 x 16.7 x 14	27.5 x 16.7 x 14
Gel Size cm	11 x 11	14 x 10	14 x 14
Recommended buffer volume: with gel tray	550 ml	700 ml	750 ml
Distance between electrodes	20 cm	19 cm	25 cm
Voltage limit	250VDC	250VDC	250VDC

#### 1.3 Safety

Power to the MGU-402T, MGU-502T or MGU-602T unit is to be supplied by an external DC voltage power supply that must be ground isolated, so that the DC voltage output floats with respect to ground. For any power supply used, the maximum specified operating parameters for the units are:

##### Maximum Limits

250VDC voltage  
15 watts power  
60 mA current  
55°C ambient temperature



Current to the unit, provided from the external power supply, must enter the unit through the lid assembly, providing a safety interlock to the user. Current to the unit is broken when the lid is removed. **Do not attempt to use the unit without the safety lid, and always turn the power supply off before removing the lid, or when working with the unit in any way. Follow safety precautions specified by the power supply manufacturer.**



## SECTION 2

### Description of Parts

#### 2.1 Unpacking

Please verify that your unit comes complete with the following components:

- Midi-Horizontal electrophoresis unit
- Tapered baffles (2)
- Safety cover with attached DC power leads
- UV Transparent slotted gel tray
- Comb with adjustable height backing.

#### 2.2 Components/Assembly

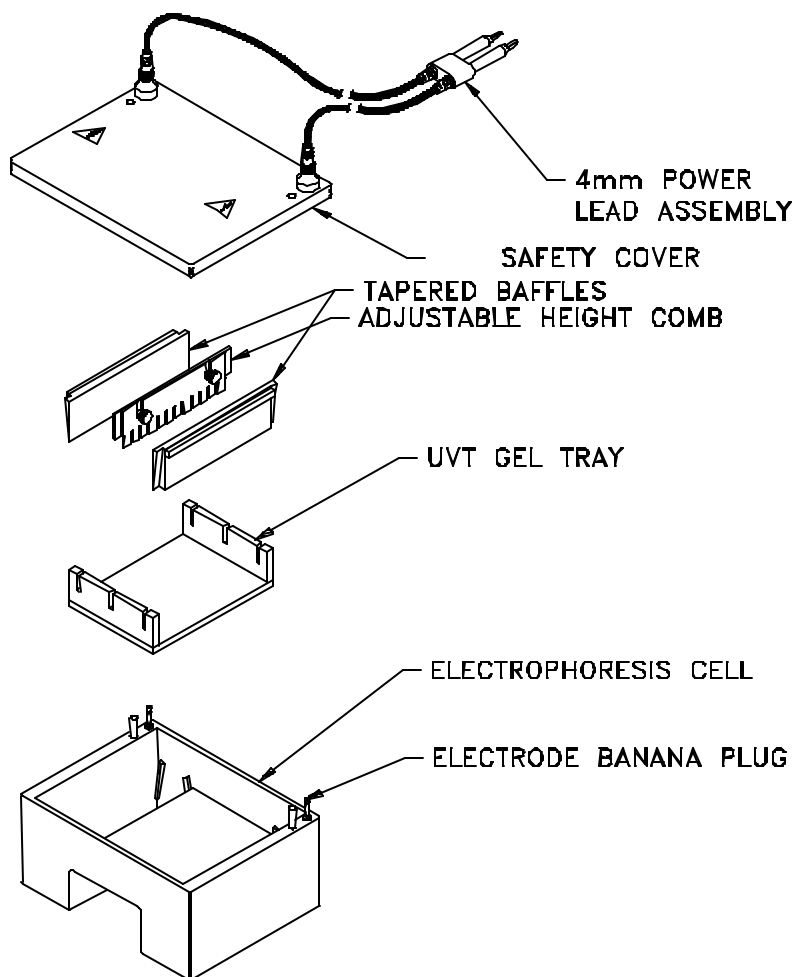



## SECTION 3

### Instructions for Use

#### 3.1 Midi-Gel Unit Preparation and Gel Casting



Place Midi-Gel unit on a level work surface in an authorized work area. Place the adjustable height comb assembly in the gel tray. Loosen the white screws holding the comb to the backing and adjust comb depth (generally 2mm). Gently tighten the adjusting screws and set the comb aside. **See Table 1 for comb volumes.**

The Midi-Gel unit provides the user with two options for gel casting: (a) **gel casting directly into unit using gel tray** or (b) **gel casting in gel tray outside of unit.**

##### A. Casting Directly into Unit Using Gel Tray.

1. Place gel tray onto raised bed of unit. Insert the tapered baffles, simultaneously on either side of gel tray and slide into the grooves next to the bed, handles to the outside. The tapered baffles will rest friction tight against the gel tray. **DO NOT** press baffles too tightly into stops.

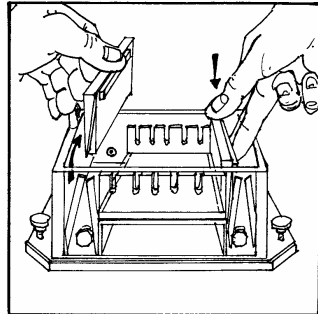
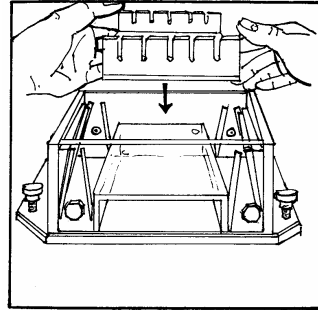

2. Position the gel comb(s). Remembering, current travels from negative (black cathode) towards positive (red anode). Pour the agarose solution onto the gel bed. Allow the agarose slab to cool uncovered until it turns opaque. Agarose around combs will take a few more minutes to cool than other parts of the slab.

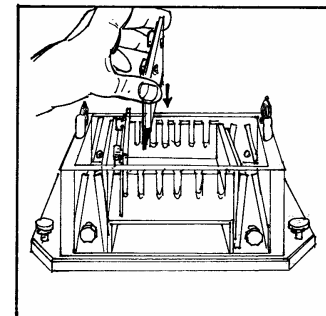

3. Slide the baffles out of their slots and store in the slots provided at either end of the unit near both terminals.

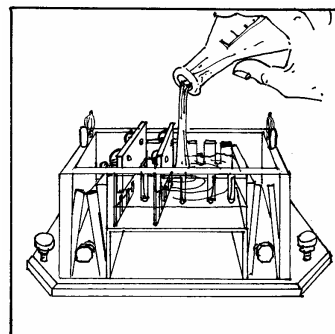

## B. Gel Casting into Gel Tray Outside of Unit.

1. Tape both ends of gel tray with tape.

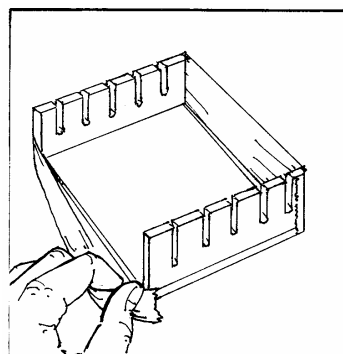

2. Place gel comb(s) into desired slot(s) in the gel tray. Using a pipette or a pipettor, run a bead of agarose solution along the edges of the gel tray where it meets the tape to assure a leak-proof seal. Then pour the agarose solution onto the gel tray. Allow the agarose slab to cool uncovered until it turns opaque. NOTE: (Optional storage) Pre-cast gels can be stored for up to one month if wrapped in plastic wrap and stored at 4°C. Remove combs prior to storing.

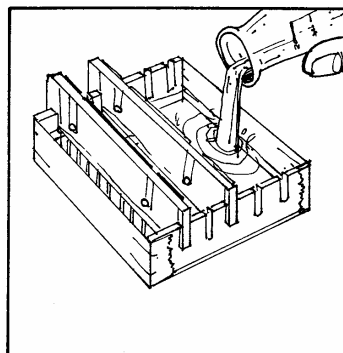

3. Remove gel tape at each end. Position the tray in the unit, remembering, current travels from negative (black cathode) towards positive (red anode).

## 3.2 Running the gel

1. Add enough buffer to fill both reservoirs and overflow the surface of the gel to a depth of 2-3mm. Gently remove comb(s). Flush out any air bubbles in the wells. Load the samples into the sample wells. NOTE: DO NOT FORGET TO LOAD DNA SIZE STANDARD.

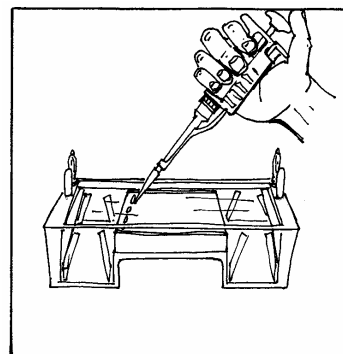

- Align safety cover over the unit and carefully attach, so not to disturb samples.

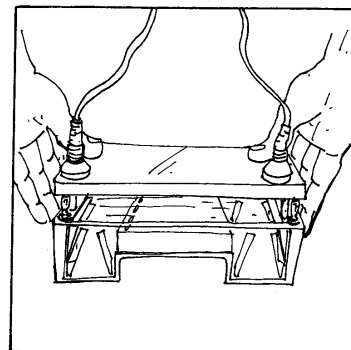

- Connect the leads to the power supply, matching the color-coded red to red and black to black. **See Section 4.1 for recommended power conditions.** Begin separation by electrophoresis.

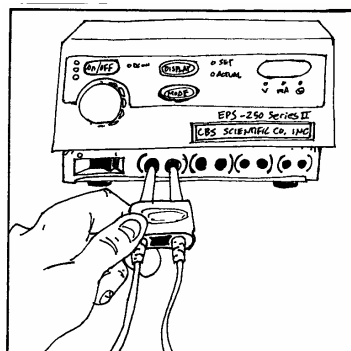

### 3.3 Removing the Gel



- Turn the power supply off and disconnect the leads from the power supply.

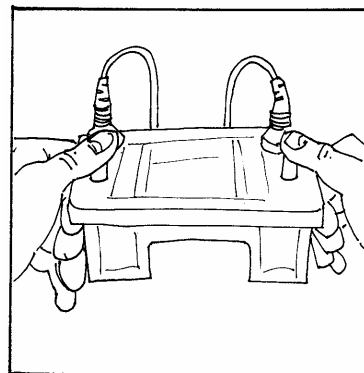

- Remove the safety cover from the unit, by placing thumbs on white posts next to red & black connectors, then pushing down while pulling up with fingers under lid. **DO NOT pull on power cords.**



- Gently lift the gel tray from the unit. **Always wear gloves, eye protection and protective clothing** if buffer and/or gel contains Ethidium Bromide. Ethidium Bromide is a powerful mutagen, gloves, eye protection and protective clothing should always be worn when handling the gel or buffer solutions. See Material Data Safety Sheets.

- View separated fragments under UV light, using proper protection for eyes and skin (see manufacturer's instructions).

### 3.4 Maximum Well/Comb Volumes

**NOTE: To calculate sample well volume expressed in millimeters (mm) of height, divide maximum volume by tooth depth.**

MBU Comb for MGU-402T # of wells	Tooth Depth mm	Overall length of comb mm	Spacing between teeth mm	Tooth width/mm	1.0mm thickness volume per tooth microliters (ul)	1.5mm thickness volume per tooth microliters (ul)	2.0mm thickness volume per tooth microliters (ul)	3.0mm thickness volume per tooth microliters (ul)
5	12.7	87.28	1.58	16.2	205.74	308.61	411.48	617.22
12	12.7	87.28	1.58	5.83	74.04	111.06	148.08	222.12
18	12.7	87.28	1.58	3.37	42.79	64.19	85.58	128.37
SGC14 Comb for MGU-502T & MGU-602T # of wells	Tooth Depth mm	Overall length of comb mm	Spacing between teeth mm	Tooth width/mm	1.0mm thickness volume per tooth microliters (ul)	1.5mm thickness volume per tooth microliters (ul)	2.0mm thickness volume per tooth microliters (ul)	3.0mm thickness volume per tooth microliters (ul)
1	12.7	120.64	3	120	1524	2286	3048	4672
3E	12.7	120.64	3	38.1	483.87	725.81	967.74	1451.61
5	12.7	120.64	3	21.6	274	411.48	548	822
10	12.7	120.64	3	9.2	117	175.26	232	350
12	12.7	120.64	2.4	7.8	99	148.59	198	297
13	12.7	120.64	2.4	6.6	83.82	125.73	167.64	251.46
16	12.7	120.64	2.4	5.3	67.3	100.9	134.6	201
20	12.7	120.64	1.6	4.5	57	85.7	114	171
26	12.7	120.64	1.6	3.1	39.3	59	78	118
27	12.7	120.64	1.6	2.93	37.21	55.82	74.42	111.63

## SECTION 4

### Running Conditions

#### 4.1 Recommended Power



As a rule, optimal resolution of larger molecules is achieved during longer runs at lower voltages, whereas smaller molecules require shorter runs at higher voltages. Applied voltage gradients can therefore be anywhere in the range of 1-10 VDC/cm of gel. Using the standard buffer systems listed below, most runs will use 5 VDC/cm as a general rule.



The usual run time will vary for the voltage chosen but should range from 15 to 60 minutes. Nucleic acid migration is monitored by the progress of marker dyes. Constant power is not a necessity, but it produces uniform heat throughout the run, therefore minimizing band diffusion. Be sure the polarity is correct i.e. that the DNA is loaded near the cathode (black electrode) to run toward the anode (red terminal).

Agarose gels may be stored for several days at 4°C wrapped in plastic wrap. Seakem Agarose (FMC) is used (normally) for preparative and analytical gels. Other types of agarose can be used for special purposes.

#### 4.2 Recommended Buffers\*

Type*	Concentrated Stock/liter	Final Concentration
TAE (Tris-acetate)	50X - 242 gm Tris base 57.1ml glacial acetic acid 100 ml 0.5M EDTA (pH 8.0)	1X - 0.04M Tris-acetate 0.001M EDTA
TBE (Tris-borate)	5X - 54 gm Tris base 27.5 gm boric acid 20 ml 0.5M EDTA (pH 8.0)	0.5X - 0.045M Tris-borate 0.001M EDTA

10X - Loading Buffer (DNA)\*  
0.25% Bromophenol blue

0.25% Xylene cyanol  
20% Ficoll Type 400  
0.1M EDTA, pH 8.0



#### Ethidium Bromide Staining

EtBr can be premixed with buffers and agarose for use during electrophoresis. Add to agarose only after temperature has fallen below 55°C. Gels can also be stained after electrophoresis in a soaking tray. Use EtBr at a final concentration of 0.1µg/ml from a 1mg/ml stock solution. Ethidium Bromide is a powerful mutagen. ALWAYS wear gloves, eye protection and protective clothing. Dispose of solutions in accordance with the safety regulations of your institution.

### 4.3 References

1. Hames, B.D., Rickwood, D. (ed.) (1990). *Gel Electrophoresis of Nucleic Acids. A Practical Approach*. 2<sup>nd</sup> edn. IRL Press, Oxford. Ch. 2.
2. Sambrook, J., Fritsch, E.F., Maniatis, T. (1989). *Molecular Cloning. A Laboratory Manual*. 2<sup>nd</sup> edn. Cold Spring Harbor Laboratory Press, Cold Spring Harbor, New York. Ch 6.
3. Ausubel, F.M., Brent, R., Kingston, R.E., Moore, D.D., Seidman, J.G., Smith, J.A., Struhl, K. (ed) (1993). *Current Protocols in Molecular Biology*. Vol. 1, Greene Publishing Associates, Inc. and John Wiley & Sons, Inc., Ch. 2.

## SECTION 5

### Maintenance of Equipment

#### 5.1 Care and Handling

The plastic components of the Midi-Horizontal units are fabricated from acrylic and polycarbonate. Electrodes and connectors are made from pure platinum, stainless steel, and chrome plated brass. As with any laboratory instrument, adequate care ensures consistent and reliable performance.

After each use, rinse buffer chamber, gel tray and combs with de-ionized water. Wipe dry with a soft cloth or paper towel, or allow to air dry. Whenever necessary, all components may be washed gently with water and a non-abrasive detergent, and rinsed and dried as above. Never use abrasive cleaners, glass cleaning sprays or scouring pads to clean the components, as these will damage the unit and components.

Additional precautions:

- Do not autoclave or dry-heat sterilize the apparatus or components.
- Do not expose the apparatus or components to phenol, acetone, benzene, halogenated hydrocarbon solvents or undiluted alcohol's.
- Avoid prolonged exposure of the apparatus or components to UV light.
- Do NOT treat with diethylpyrocarbonate (DEPC)-treated water for extended periods at 37°C. A brief rinse with DEPC-water is sufficient after a thorough wash, followed by a quick rinse in 70% ethanol.

#### 5.2 Maintenance

The following inspection and maintenance procedures will help maintain the safety and reliable performance of the Midi-Horizontal systems. Replacement parts can be ordered by call 1-858-755-4959 or by contacting your local distributor.

- Banana plugs and power cords should be inspected regularly. If the banana plugs become loose or do not feel friction tight replace the plugs or power cords.
- Should power cord assemblies (connectors, wire or shrouds) show any signs of wear or damage (e.g. cracks, nicks, abrasions, or melted insulation), replace them immediately.



- The platinum wire is secured to the banana jack by compression between a stainless washer and the jack nut. The nut/washer interface should be tight and free of corrosion.

## SECTION 6

### Horizontal Midi-Gel Kits and Accessories

Cat.#	Item
<b>MGU-402T</b>	<b>Horizontal Midi-Gel Kit-CE</b> , with tapered baffles. Gel bed dimensions are 11cm x 11cm. Includes one comb, UVT gel tray and safety cover. Please specify comb cat. # from list below.
<b>MGU-402T-FL</b>	<b>Horizontal Midi-Gel Kit-CE with Flip Lid</b> , with tapered baffles. Gel bed dimensions are 11cm x 11cm. Includes one comb, UVT gel tray and safety cover. Please specify comb cat. # from list below.
<b>MGU-502T</b>	<b>Double-Wide Midi-Gel Kit-CE</b> , with tapered baffles. Gel bed dimensions are 14cm x 10cm. Includes one comb, UVT gel tray and safety cover. Please specify comb cat. # from list below.
<b>MGU-502T-FL</b>	<b>Double-Wide Midi-Gel Kit-CE with Flip Lid</b> , with tapered baffles. Gel bed dimensions are 14cm x 10cm. Includes one comb, UVT gel tray and safety cover. Please specify comb cat. # from list below.
<b>MGU-602T</b>	<b>Horizontal Midi-Gel Kit-CE</b> , with tapered baffles. Gel bed dimensions are 14cm x 14cm. Includes one comb, UVT gel tray and safety cover. Please specify comb cat. # from list below.
<b>MGU-602T-FL</b>	<b>Horizontal Midi-Gel Kit-CE with Flip Lid</b> , with tapered baffles. Gel bed dimensions are 14cm x 14cm. Includes one comb, UVT gel tray and safety cover. Please specify comb cat. # from list below.

#### Color Coded Midi-Gel Option:

Available for the MGU-402T, MGU-502T and MGU-602T models. To specify color desired, please add the following color code to the end of the catalog number: -Y (Yellow), -P (Purple), -B (Blue), -PK (Pink), or -G (Green). For example, to specify a green MGU-402T place order for catalog # MGU-402T-G.

### MIDI-GEL ACCESSORIES

#### MGU-402T combs (Available in Polycarbonate, or Teflon-Coated Aluminum\*\*)

Cat.#	Comb Dimensions
MBU-1005	1mm x 5 well
MBU-1010	1mm x 10 well**
MBU-1012	1mm x 12 well
MBU-1018	1mm x 18 well
MBU-1505	1.5mm x 5 well
MBU-1510	1.5mm x 10 well**
MBU-1512	1.5mm x 12 well
MBU-1518	1.5mm x 18 well

\*\* To specify Teflon combs add "-TF" to end of cat. #.

#### MGU-502T and MGU-602T combs (Available in Polycarbonate, or Teflon-Coated Aluminum\*\*)

Cat.#	Comb Dimensions	Cat.#	Comb Dimensions
SGC14-1001	1mm x 1 well	SGC14-2001	2mm x 1 well
SGC14-1003E	1mm x 3 equal wells	SGC14-2003E	2mm x 3 equal wells
SGC14-1003M	1mm x 2 well + middle marker	SGC14-2003M	2mm x 2 well + middle marker
SGC14-1005	1mm x 5 well	SGC14-2005	2mm x 5 well
SGC14-1008	1mm x 8 well	SGC14-2008	2mm x 8 well
SGC14-1010	1mm x 10 well	SGC14-2010	2mm x 10 well
SGC14-1012	1mm x 12 well	SGC14-2012	2mm x 12 well
SGC14-1013	1mm x 13 well*	SGC14-2013	2mm x 13 well*
SGC14-1016	1mm x 16 well	SGC14-2016	2mm x 16 well
SGC14-1020	1mm x 20 well	SGC14-2020	2mm x 20 well
SGC14-1026	1mm x 26 well	SGC14-2026	2mm x 26 well
SGC14-1027	1mm x 27 well*	SGC14-2027	2mm x 27 well*
SGC14-1501	1.5mm x 1 well	SGC14-3001	3mm x 1 well
SGC14-1503E	1.5mm x 3 equal wells	SGC14-3003E	3mm x 3 equal wells
SGC14-1503M	1.5mm x 2 well + middle marker	SGC14-3003M	3mm x 2 well + middle marker
SGC14-1505	1.5mm x 5 well	SGC14-3005	3mm x 5 well
SGC14-1508	1.5mm x 8 well	SGC14-3008	3mm x 8 well
SGC14-1510	1.5mm x 10 well	SGC14-3010	3mm x 10 well
SGC14-1512	1.5mm x 12 well	SGC14-3012	3mm x 12 well
SGC14-1513	1.5mm x 13 well*	SGC14-3013	3mm x 13 well*
SGC14-1516	1.5mm x 16 well	SGC14-3016	3mm x 16 well

SGC14-1520	1.5mm x 20 well
SGC14-1526	1.5mm x 26 well
SGC14-1527	1.5mm x 27 well

SGC14-3020	3mm x 20 well
SGC14-3026	3mm x 26 well
SGC14-3027	3mm x 27 well

\*Designed for multi-channel pipettor loading.

\*\* To specify Teflon combs add "-TF" to end of cat. #.

## **MIDI-GEL ACCESSORIES-CONTINUED**

### **Midi Gel Trays (UV Transparent)**

<u>Cat. #</u>	<u>Item</u>
MGT-400	Gel Tray for the MGU-402T, 2 slots. Pathlength of 4cm/slot
MGT-500	Gel Tray for the MGU-502T, 2 slots. Pathlength of 3.6cm/slot
MGT-600	Gel Tray for the MGU-602T, 2 slots. Pathlength of 3.1cm/slot

### **Replacement Baffles**

<u>Cat. #</u>	<u>Item</u>
BAFFLES-402T	Tapered Baffles for MGU-402T
BAFFLES-502T	Tapered Baffles for MGU-502T
BAFFLES-602T	Tapered Baffles for MGU-602T

### **Horizontal Gel Casters**

<u>Cat. #</u>	<u>Item</u>
GCT10-111	Gel Casting Tray for 10.5cm (w) x 11cm (l), single place
GCT10-112	Gel Casting Tray for 10.5cm (w) x 11cm (l), two place
GCT14-101	Gel Casting Tray for 14cm (w) x 10cm (l), single place
GCT14-102	Gel Casting Tray for 14cm (w) x 10cm (l), two place
GCT14-161	Gel Casting Tray for 14cm (w) x 16cm (l), single place
GCT14-162	Gel Casting Tray for 14cm (w) x 16cm (l), two place

### **Gel Tape**

<u>Cat. #</u>	<u>Item</u>
GT-72-10	Gel tape, 72 yard x 1.0"
GT-72-15	Gel tape, 72 yard x 1.5"

### **Power Supply**

<u>Cat. #</u>	<u>Item</u>
EPS-300-II	Mini Power Supply, with timer, CV or CC, 10-300V, 110V/60Hz, current range:4-500mA, 90 watts
EPS-300-IV	Mini Power Supply, with timer, CV or CC, 10-300V, 220V/50Hz, current range:4-500mA, 90 watts
EPS-3000-III	Constant Power Supply, 0-3000 Volt, 110V/60Hz, Series II
EPS-3000-IV	Constant Power Supply, 0-3000 Volt, 220V/50Hz, Series II