

# INSTRUCTION MANUAL

## Horizontal/Submarine Productivity Packages

GCSGU-014T-02  
GCSGU-020T-02  
GCSGU-030T-02  
GCSGU-040T-02

## High-Throughput Horizontal Productivity Packages

GCSGU-2614T-02  
GCSGU-2626T-02  
GCSGU-2640T-02

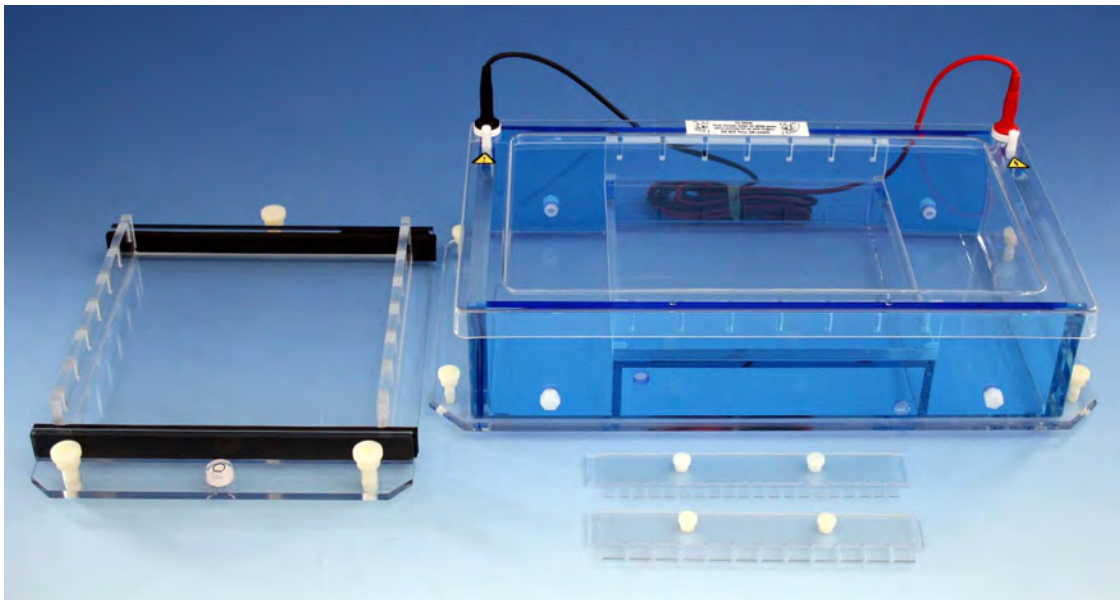

# TABLE OF CONTENTS

	Page
<b>Important User Information</b>	<b>3-4</b>
<b>Section 1    General Information</b>	
1.1    Introduction	5
1.2    Specifications	5
1.3    Safety	5
<b>Section 2    Description of parts</b>	
2.1    Unpacking	6
2.2    Components/Assembly	6
<b>Section 3    Instructions for Use</b>	
3.1    Submarine/Horizontal Unit Preparation	7
3.2    Gel Casting	7-8
3.3    Running the Gel	9
3.4    Removing the Gel	9-10
3.5    Comb Volumes	10
<b>Section 4    Running Conditions</b>	
4.1    Recommended Power	11
4.2    Recommended Buffer & Agarose Volumes	11
4.3    Recommended Buffers & Solutions	11
4.4    References	12
<b>Section 5    Maintenance of Equipment</b>	
5.1    Care and Handling	12
5.2    Maintenance	12
<b>Section 6    Equipment and Accessories</b>	<b>13-14</b>

## IMPORTANT USER INFORMATION

This Instruction Manual will explain how to use this product safely and effectively. Please read and carefully follow the instruction manual in its entirety.



The triangle/exclamation mark symbol alerts the user of the product to important operational, maintenance, and/or warranty requirements.



The triangle/lightning bolt symbol alerts the user of the product to potentially hazardous electrical exposure.







Failure to adhere to the instructions could result in personal and/or laboratory hazards, as well as invalidate any warranty. Always turn off the DC power source prior to disconnecting power cords from the product. Disconnect power cords from the power source first, and then from the product. For maximum safety, always operate this system in an isolated, low traffic area, not accessible to unauthorized personnel. Never operate damaged or leaking equipment.

## WARRANTY AND LIABILITY

This product was produced utilizing the highest practical standards of materials, workmanship, and design. C.B.S. Scientific warrants that the product has been tested and will meet or exceed published specifications. This warranty is valid only if the product has been operated and maintained according to the instructions provided.

C.B.S. Scientific warrants this product to be free from defects in materials and workmanship under normal service for one year from date of shipment. If the product proves defective during this period, C.B.S. Scientific will repair or replace it at our option, free of charge, if returned to us postage prepaid. This warranty does not cover: damage in transit, damage caused by carelessness, misuse or neglect, normal wear through frequent use, damage caused by solvent corrosion, damage caused by improper handling or user alteration, nor unsatisfactory performance as a result of conditions beyond our control. C.B.S. Scientific shall in no event be liable for incidental nor consequential damages, including without limitation, lost profits, loss of income, loss of business opportunities, loss of use and other related damages, however caused, nor any damage arising from the incorrect use of the product.

<p><b>FRANÇAIS INFORMATION IMPORTANTE À L'USAGE DES UTILISATEURS</b></p> <p>Le présent manuel d'utilisation explique la manière de se servir efficacement du produit en conditions de sécurité. Il est recommandé de soigneusement lire la totalité du manuel, avec ses consignes et ses instructions.</p> <p> Le triangle avec point d'exclamation est un symbole destiné à avertir l'utilisateur du produit de l'importance de certaines exigences relatives au fonctionnement, à l'entretien et/ou à la garantie.</p> <p> Le triangle avec flèche en zigzag est un symbole destiné à avertir l'utilisateur du produit de la possibilité d'exposition à des décharges avec danger de secousses électriques.</p> <p> Tout manquement à l'observation des consignes et des instructions peut exposer les personnes et les biens à des dommages corporels et/ou matériels et peut annuler toute garantie. Il faut toujours interrompre l'alimentation de courant continu avant de déconnecter les cordons d'alimentation du produit. Déconnecter d'abord les cordons d'alimentation branchés sur la source de tension (alimentation de secteur) puis ceux branchés sur le produit. Pour une sécurité maximum, il faut toujours faire fonctionner ce système dans un lieu isolé, peu fréquenté, où le personnel non autorisé n'a pas accès. Ne jamais faire fonctionner un matériel endommagé ou affecté par des fuites.</p> <p><b>GARANTIE ET RESPONSABILITÉ</b></p> <p>Le produit a été fabriqué conformément aux normes applicables les plus exigeantes en matière de matériaux, de main d'œuvre, de conception et d'ingénierie. C.B.S. Scientific garantit que le produit a subi des essais et que ses performances rempliront les conditions des spécifications publiées ou leur seront même supérieures. La présente garantie n'est valide que si le produit a fonctionné et a été entretenu conformément aux consignes et instructions fournies.</p> <p>C.B.S. Scientific garantit que le produit sera dépourvu de vices de matériaux et de main d'œuvre, en conditions de service normales, pendant un an à compter de la date d'expédition. Au cas où le produit s'avérerait défectueux pendant cette période de garantie, C.B.S. Scientific réparera ou remplacera le produit, à sa discrétion et gratuitement, si le produit lui est retourné port payé d'avance. La garantie ne couvre pas les dommages de transport; les dommages causés par l'imprudence, le manque de soins, l'abus ou la négligence; l'usure normale résultant d'une utilisation fréquente; les dommages causés par la corrosion des solvants; et les dommages causés par la manipulation inadéquate ou des changements apportés par l'utilisateur. La garantie ne couvre pas non plus les performances non satisfaisantes résultant de conditions hors du contrôle de C.B.S. Scientific. C.B.S. Scientific ne pourra en aucun cas être tenue responsable de dommages indirects, y compris, de manière non limitative, la perte de bénéfices, le manque à gagner, la perte d'occasions d'affaires, l'impossibilité d'usage ou tous autres dommages associés, quelle qu'en soit la cause, ni de dommages résultant de l'usage incorrect du produit.</p>	<p><b>ESPAÑOL INFORMACIÓN IMPORTANTE PARA EL USUARIO</b></p> <p>El presente instructivo explica la manera de usar este producto en forma segura y efectiva. Sírvase leerlo en su totalidad y seguir detenidamente las indicaciones que contiene.</p> <p> El símbolo del triángulo con exclamación llama la atención del usuario a requisitos importantes para el uso y mantenimiento del producto, así como para la validez de la garantía.</p> <p> El símbolo del triángulo con rayo llama la atención del usuario a la posibilidad de riesgos eléctricos.</p> <p> El incumplimiento de las instrucciones aquí señaladas podría dar lugar a riesgos a la persona, al laboratorio o a ambos y podría anular toda garantía. Siempre apague la fuente de corriente continua antes de desenchufar los cables eléctricos del producto. Primero desconecte los cables de la fuente de energía y después del producto. Para mayor seguridad, siempre use este sistema en un área aislada, de poco movimiento de personas e inaccesible a personal no autorizado. Jamás use equipo que presenta algún daño o fuga.</p> <p><b>GARANTÍA Y RESPONSABILIDAD</b></p> <p>Este producto fue fabricado de acuerdo con las normas más estrictas que sean factibles en cuanto a materiales, mano de obra y diseño. C.B.S. Scientific garantiza que se sometió el producto a pruebas y que cumplirá o excederá las especificaciones publicadas. Esta garantía será válida únicamente si se usa y se da servicio de mantenimiento al producto de acuerdo con las instrucciones señaladas.</p> <p>C.B.S. Scientific garantiza que este producto se encontrará libre de defectos de materiales y mano de obra por un período de servicio normal de un año a partir de la fecha de embarque. Si el producto resulta defectuoso durante este período, C.B.S. Scientific lo reparará o lo repondrá, a criterio de C.B.S., libre de cargos, si se devuelve el producto a C.B.S. porte pagado. Esta garantía no cubre daños sufridos en tránsito, daños provocados por descuido, mal uso o negligencia, desgaste normal como consecuencia del uso excesivo, daños atribuidos a corrosión provocada por solventes, daños causados por el uso indebido o alteraciones realizadas por el usuario ni rendimiento insatisfactorio atribuible a circunstancias fuera del control de C.B.S. Scientific. C.B.S. Scientific en ningún caso asumirá responsabilidad por daños incidentales o subsecuentes, incluyendo, en forma no limitativa, la pérdida de utilidades, de ingresos, de oportunidades comerciales o del uso del producto y otros daños afines, fuere cual fuere su origen, ni por daños derivados del uso incorrecto del producto.</p>
<p><b>DEUTSCH WICHTIGE INFORMATION FÜR DEN BENUTZER</b></p> <p>Diese Bedienungsanleitung beschreibt wie man dieses Produkt sicher und wirksam benutzt. Bitte lesen und befolgen Sie alle Anweisungen in dieser Anleitung.</p> <p> Das Dreieck mit Ausrufezeichen weist den Benutzer des Produktes darauf hin, daß wichtige Bedienungs-, Wartungs- und/oder Garantievorschriften zu beachten sind.</p> <p> Das Dreieck mit Zickzackblitz warnt den Benutzer des Produktes vor möglichen Gefahren durch elektrische Spannungen.</p> <p> Nichtbeachtung dieser Anweisungen kann zu persönlichen und/oder labortechnischen Schäden führen und gleichzeitig alle Garantien als nichtig erklären. Die DC Stromzufuhr muß immer, vor dem Entfernen der Stromkabel vom Produkt, abgeschaltet werden. Die Stromzufuhrkabel müssen zuerst von der Steckdose und erst dann vom Produkt entfernt werden. Um höchste Sicherheit zu gewährleisten sollte dieses System in einem abgesonderten und besonders ruhigen Bereich eingesetzt werden und vor Unbefugten sicher sein.</p> <p><b>GARANTIE UND HAFTUNG</b></p> <p>Dieses Produkt wurde unter Anwendung von Produkten mit höchster Qualität und aus Materialien mit bester Verarbeitung und modernstem Design hergestellt. C.B.S. Scientific garantiert, daß das Produkt getestet wurde und alle publizierten Spezifikationen übertrifft. Diese Garantie ist jedoch nur gültig, wenn das Produkt nach der beigefügten Bedienungsanleitung bedient und gewartet wurde.</p> <p>C.B.S. Scientific garantiert, daß dieses Produkt bei normaler Bedienung aus fehlerfreiem Material besteht und fehlerfrei in der Ausführung ist. Diese Garantie gilt für ein Jahr ab Lieferdatum. Sollte das Produkt in diesem Zeitraum fehlerhaft werden, bietet C.B.S. Scientific eine kostenlose Reparatur bzw. kostenlosen Ersatz, einschließlich freiem Rückporto. Diese Garantie schließt folgendes aus: Transportschaden, Schaden durch Nachlässigkeit, Mißbrauch oder Vernachlässigung, normale Abnutzung durch regelmäßigen Gebrauch, Schaden durch Säureangriff, Schaden durch falsche Handhabung, Veränderung des Produktes durch den Benutzer, oder unzureichende Leistungen die sich nicht im Verantwortungsbereich von C.B.S. Scientific befinden. C.B.S. Scientific kommt unter keinen Umständen für folgende Schäden auf: Sachschadensverlust, Einkommensverlust, Verlust von Geschäftsmöglichkeiten, Verwundung der Anwendung und andere damit verbundene Schäden die auf irgend eine Art und Weise entstanden sind, oder Schäden die aus falscher Anwendung des Produktes entstanden sind.</p>	<p><b>ITALIANO INFORMAZIONI IMPORTANTI PER L'UTENTE</b></p> <p>Questo manuale spiega come utilizzare questo prodotto in maniera sicura ed efficiente. Si preghi di leggere e seguire con cautela le istruzioni di ogni parte di questo manuale.</p> <p> Il triangolo contenete il simbolo di un punto esclamativo avverte l'utente di importanti requisiti relativi al funzionamento, manutenzione e/o garanzia del prodotto.</p> <p> Il triangolo contenete il simbolo di un lampo avverte l'utente del prodotto della possibilità di pericoli dovuti a corrente elettrica.</p> <p> La mancata osservanza delle istruzioni può essere causa di pericolo alla propria persona ed al laboratorio, oltre a poter annullare la garanzia. Prima di distaccare il cordone d'alimentazione dal prodotto, spegnere sempre la sorgente di corrente continua. Distaccate i cordoni d'alimentazione prima dal lato della sorgente di tensione e poi dal lato del prodotto. Per maggior sicurezza, mettere sempre in funzione il prodotto in un'area isolata con poco traffico che non sia accessibile al personale non autorizzato. Non mettere mai in funzione un'apparecchiatura che sia danneggiata o abbia perdite.</p> <p><b>GARANZIA E RESPONSABILITÀ</b></p> <p>Questo prodotto è stato fabbricato seguendo gli standard più elevati per i materiali, la manodopera e la progettazione. La C.B.S. Scientific garantisce il prodotto è stato sottoposto a prova e raggiunge o supera i valori pubblicati per i dati tecnici. Questa garanzia è valida solo se il prodotto è messo in esercizio e soggetto a manutenzione secondo le istruzioni fornite.</p> <p>La C.B.S. Scientific garantisce che questo prodotto è libero di difetti di materiali e manodopera, in normali condizioni d'esercizio, per la durata di un anno dalla data di spedizione. Se, in questo periodo, il prodotto si dimostrerà difettoso, la C.B.S. Scientific, a suo giudizio, lo riparerà o sostituirà. Questa garanzia non copre danni in transit, danni causati da negligenza, uso improprio, trascuratezza, normale consumo derivante da uso frequente, o danni causati da solventi corrosivi, danni causati da maltrattamento o da modifiche apportate dall'utente e non copre prestazioni insoddisfacenti che siano il risultato di condizioni al di fuori del controllo del fabbricante. La C.B.S. Scientific non sarà in ogni caso responsabile per danni incidentali o consequenziali, incluso, senza limitazioni, perdite di profitto, perdita di entrate, perdita di opportunità d'affari e altri danni relativi, comunque causati, e per danni risultanti da uso incorretto del prodotto.</p>

# SECTION 1

## General Information

### 1.1 Introduction

The Submarine/Horizontal Gel units offer gel sizes (14 x 20cm) GCSGU-014T-02, (20 x 20cm) GCSGU-020T-02, (20 x 30cm) GCSGU-030T-02, (20 x 40cm) GCSGU-040T-02, (26 x 14cm) GCSGU-2614T-02 (26 x 26cm) GCSGU-2626T-02, and GCSGU-2640T-02 (26cm x 40cm). In the Submarine/Horizontal gel units, the unique tapered baffle system allows immediate gel casting directly onto the removable UV transparent gel tray without having to seal with agar or tape. Casting can also be done outside the unit by placing the gel tray into the friction-fit external gel casting tray. The UV transparent slotted gel tray configuration allows for single or multiple sample separations. When the gel tray is used in combination with multiple sample combs, designed for multi-channel pipette loading, screening of large sample numbers can be easily facilitated. The Submarine/Horizontal Gel units come equipped with an integral cooling chamber for temperature control and recirculation ports for proper maintenance of buffer pH.

### 1.2 Specifications

#### Constructions:

<b>Buffer chamber, safety cover</b>	Acrylic
<b>Electrodes</b>	Platinum wire .010" diameter
<b>Power cords</b>	FR silicone rated 7500VDC, 200mA, 65°C
<b>Tapered baffles</b>	Acrylic
<b>Combs</b>	Polycarbonate, Anodized Aluminum or Teflon
<b>Adjustable comb backing</b>	Acrylic or anodized aluminum
<b>UVT Gel Tray</b>	UV transparent acrylic
<b>Safety Certification</b>	EN61010-1-1993 (IEC1010-1)

	SGU-014T-02	SGU-020T-02	SGU-030T-02	SGU-040T-02	SGU-2614T-02	SGU-2626T-02	SGU-2640T-02
Shipping Weight	9 lb.	11 lb.	15 lb.	19 lb.	12 lb.	16 lb.	20lb.
Overall Size (l)x(w)x(h) cm	38 x 15 x 10	43 x 21 x 10	53 x 21 x 10	63 x 21 x 10	38 x 28 x 10	48 x 28 x 10	64 x 28 x 10
Gel Size - cm	14 x 20	20 x 20	20 x 30	20 x 40	26 x 14	26 x 26	26 x 40
Recommended buffer volume with gel tray mls	1500	1850	1950	2050	2200	2600	3400
Distance between electrodes -cm	33	38	48	58	30	43	55
Voltage limit	500 VDC	500 VDC	600 VDC	600 VDC	500 VDC	500 VDC	600 VDC

### 1.3 Safety



Power to the Submarine/Horizontal gel units is to be supplied by an external DC voltage power supply that must be ground isolated so that the DC voltage output floats with respect to ground. For any power supply used, the maximum specified operating parameters for the units are:

#### Maximum Limits

500-600 VDC  
 20 watts power  
 90mA current  
 55°C ambient temperature



Current to the unit, provided from the external power supply, must enter the unit through the lid assembly, providing a safety interlock to the user. Current to the unit is broken when the lid is removed. **Do not attempt to use the unit without the safety lid, and always turn the power supply off before removing the lid, or when working with the unit in any way. Follow safety precautions specified by the power supply manufacturer.**

## SECTION 2 Description of Parts

### 2.1 Unpacking

Please verify that your unit comes complete with the following components:

- Submarine Horizontal electrophoresis unit
- Tapered baffles (2)
- Safety cover with attached DC power leads
- 2 each UV Transparent slotted gel trays
- 2 Adjustable height combs (of your choice) for 14cm(w) or 20cm(w)  
or 4 Adjustable height combs for 26cm(w) High Throughput Horizontals
- White tubing adapters for buffer and coolant circulation
- Bubble level
- External Gel Caster (not illustrated below)

### 2.2 Components/Assembly

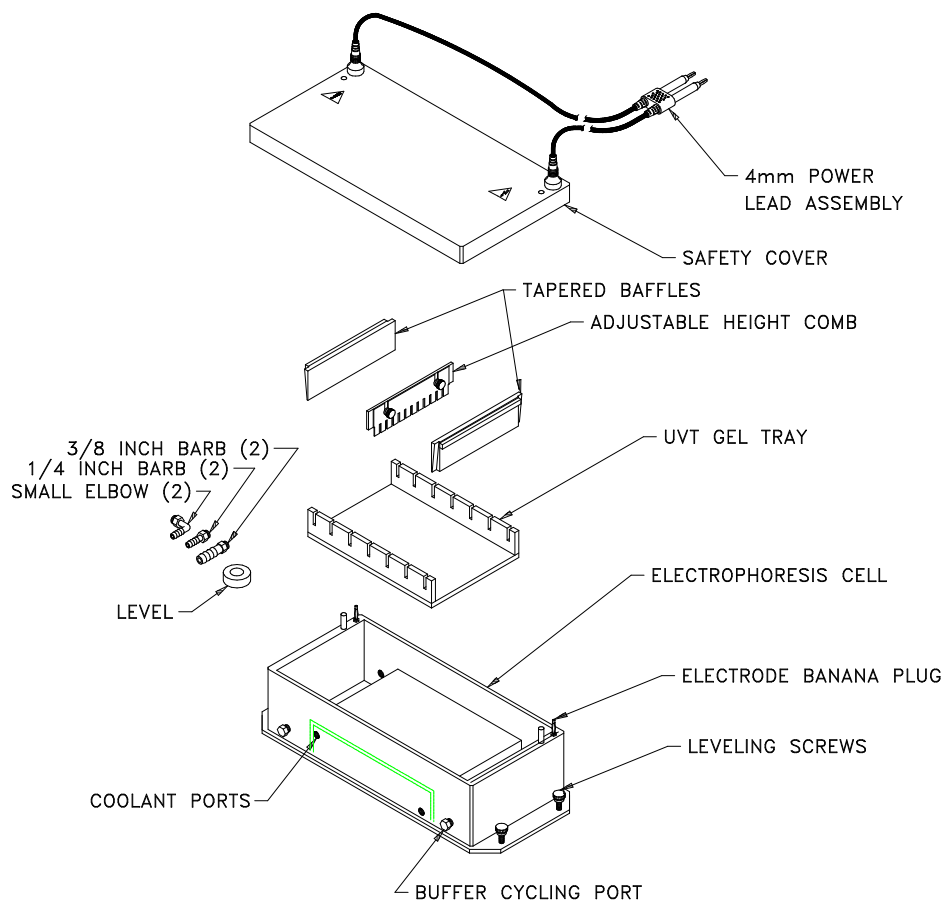

## SECTION 3 Instructions for Use

### 3.1 Submarine/Horizontal Unit Preparation



Place Submarine/Horizontal unit on a level work surface in an authorized work area. Level the unit by placing the bubble level in the center of the unit and adjusting the four leveling screws on the of base until the unit is level.

Place the adjustable height comb(s) assembly in the gel tray. Loosen the white screws holding the comb to the backing and adjust comb depth (generally 2mm). Gently retighten the adjusting screws and set the comb aside. **See Table 1 and 2 for comb volumes.**



#### Coolant Circulation:

A selection of white tubing adapters (right angled and straight) is provided with each unit. For coolant circulation, screw tubing adapters into fittings on side of internal cooling chamber, located under the gel bed. Connect a heavy wall tubing which will not kink (if tubing kinks, excessive pressure build-up may damage unit and create coolant leaks) and attach a regulated pump or recirculating water bath (follow manufacturer's instructions). Flow rate is not to exceed 3 liters per minute. **Do NOT** use tap or house water as it can be subject to large fluctuations in pressure.

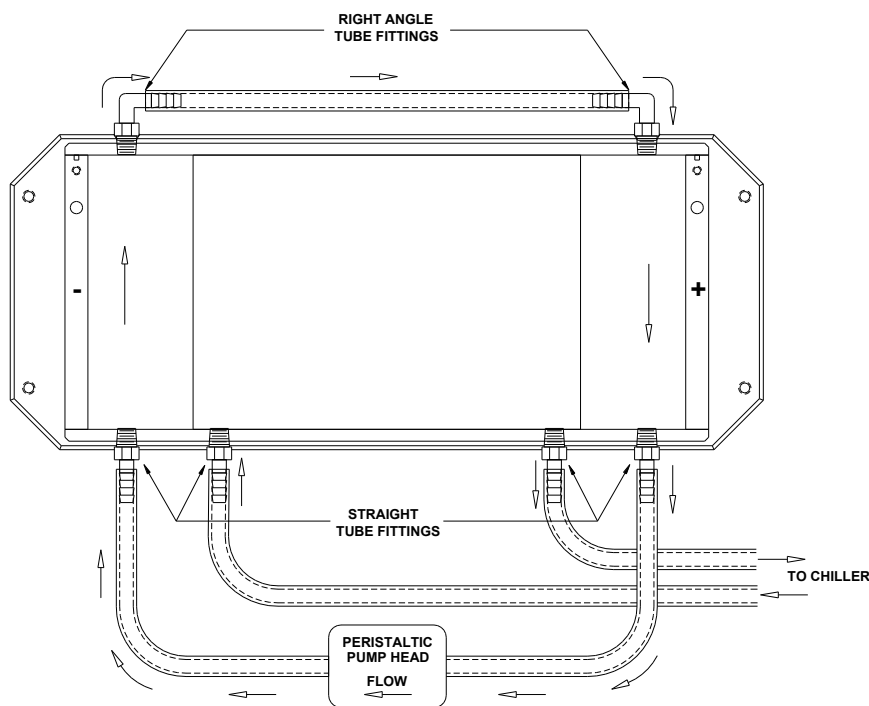

#### Buffer Recirculation:

Buffer recirculation is recommended for longer runs to maintain uniform pH and ionic strength and to reduce buffer changes. Unit is shipped with buffer circulation ports sealed with four white plugs. For cycling buffer, remove plugs and replace with threaded tubing adapters. Using tubing adapters and pump, cycle buffer from anode (+) to cathode (-).

## 3.2 Gel Casting

The Submarine/Horizontal gel unit provides the user with two options for gel casting: (a) **gel casting directly into unit using gel tray** or (b) **gel casting in gel tray outside of unit**.

### A. Casting Directly into Unit Using Gel Tray.

1. Place gel tray onto raised bed of unit. Insert the tapered baffles **simultaneously** on either side of gel tray and slide them into the grooves next to the bed, handles to the outside. The tapered baffles will rest friction tight against the gel tray.

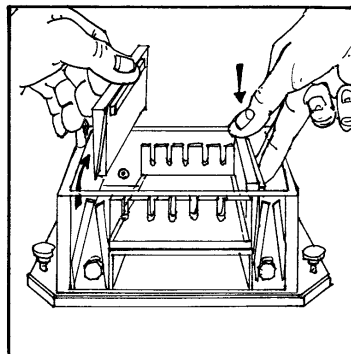
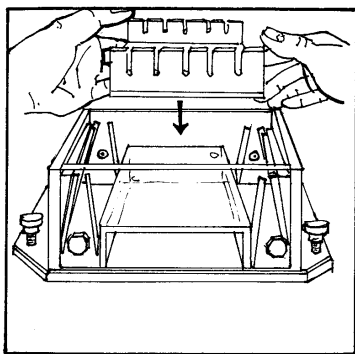

2. Place gel comb(s) into desired slot(s) provided on gel tray. Remember, current travels from negative (black cathode) towards positive (red anode). Pour the agarose solution onto the gel bed. Allow the agarose slab to cool uncovered until it turns opaque. Agarose around combs will take a few more minutes to cool than other part of the slab.

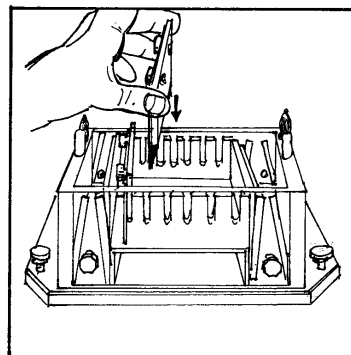

3. Slide the baffles out of their slots and store in the slots provided at either end of the unit near both terminals.

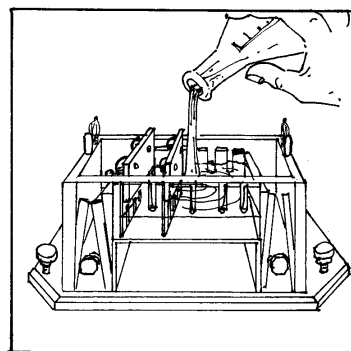

## B. Gel Casting in External Gel Caster.

1. Level external gel caster with leveling screws on base. Push one of the open sides of gel tray against black gasket.



2. Push down on gel tray until flat against bottom of tray and so both sides friction fit against the black gaskets.



3. Place gel comb(s) into desired slot(s) in gel tray and pour in hot agarose. When agarose has cooled place gel tray into Horizontal Unit. Remember, current travels from negative (black cathode) towards positive (red anode).

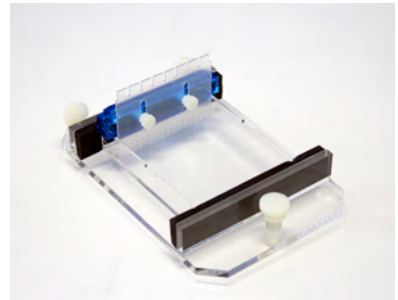

## 3.3 Running the Gel

1. Add enough buffer to fill both reservoirs and overflow the surface of the gel to a depth of 2-3mm. Gently remove comb(s). Flush out any air bubbles in the wells. Load the samples into the sample wells.

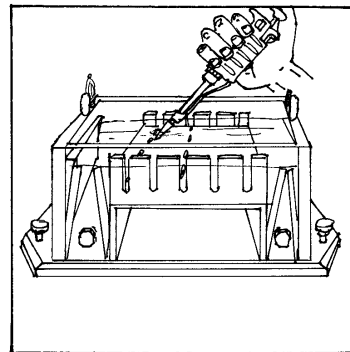
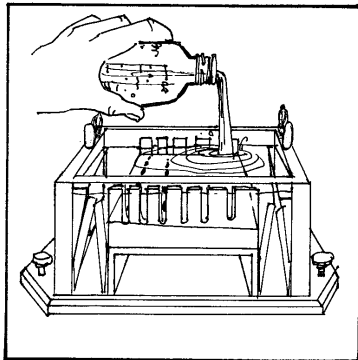

- Align safety cover over the unit and carefully attach, so not to disturb samples. Begin cycling of coolant and buffer (if used).

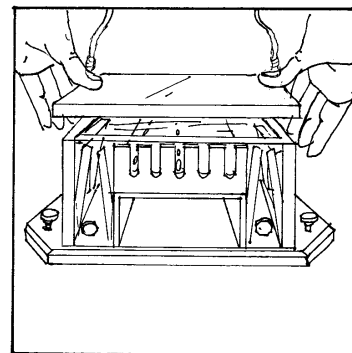

- Connect the leads to the power supply, matching the color-coded red to red and black to black. **See Section 4.1 for recommended power conditions.** Begin separation by electrophoresis.

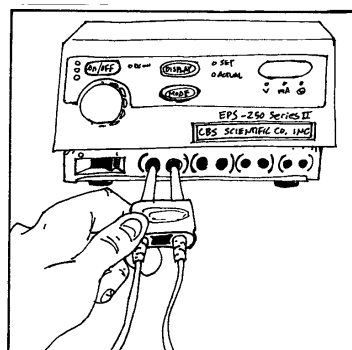

### 3.4 Removing the Gel



- Turn the power supply off and disconnect the leads from the power supply.
- Remove the safety cover from the unit, by placing thumbs on white posts next to red & black connectors, then pushing down while pulling up with fingers under lid. **DO NOT pull on power cords.**

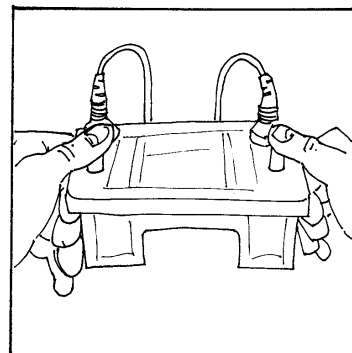

- Gently lift the gel tray from the unit. **Always wear gloves, eye protection and protective clothing** if buffer and/or gel contains Ethidium Bromide. Ethidium Bromide is a powerful mutagen, gloves, eye protection and protective clothing should always be worn when handling the gel or buffer solutions. See Material Data Safety Sheets.
- View separated fragments under UV light, using proper protection for eyes and skin (see manufacturer's instructions).

### 3.5 Maximum Well/Comb Volumes

**NOTE: To calculate sample well volume expressed in millimeters (mm) of height, divide maximum volume by tooth depth.**

**TABLE 1---Combs for 14cm wide unit**

SGC14 Combs for 14cm wide unit  # of wells	Tooth Depth mm	Spacing between teeth mm	Overall length of comb mm	Tooth width/ mm	1.0mm thickness volume per tooth microliters (ul)	1.5mm thickness volume per tooth microliter s (ul)	2.0mm thickness volume per tooth microliters (ul)	3.0mm thickness volume per tooth microliters (ul)
1	12.7	3	120.64	120	1524	2286	3048	4572
3E	12.7	3	120.64	38.1	483.87	725.81	967.74	1451.61
5	12.7	3	120.64	21.6	274	411.48	548	822
10	12.7	3	120.64	9.2	117	175.26	232	350
12	12.7	2.4	120.64	7.8	99	148.59	198	297
13	12.7	2.4	120.64	6.6	83.82	125.73	167.64	251.46
16	12.7	2.4	120.64	5.3	67.3	100.9	134.6	201
20	12.7	1.6	120.64	4.5	57	85.7	114	171
26	12.7	1.6	120.64	3.1	39.3	59	78	118
27	12.7	1.6	120.64	2.93	37.21	55.82	74.42	111.63

**TABLE 2---Combs for 20cm wide unit**

SGC20 Combs for 20cm wide unit  # of wells	Tooth Depth mm	Spacing between teeth mm	Overall length of comb mm	Tooth width/ mm	1.0mm thickness volume per tooth microliters (ul)	1.5mm thickness volume per tooth microliters (ul)	2.0mm thickness volume per tooth microliters (ul)	3.0mm thickness volume per tooth microliters (ul)
1	12.7	3.17	180	180	2286	3429	4572	6858
3E	12.7	3.17	180	49.73	631.57	947.35	1263.14	1894.71
3M	12.7	3.17	180	73.66	935.48	1403.22	1870.96	2806.44
5	12.7	3.17	180	33	419	628	838	1257
8	12.7	2.38	180	20.5	160.3	390	520.6	780
12	12.7	2.38	180	12.8	162.5	243	325	487.6
16	12.7	2.38	180	9	115	172	230	345
20	12.7	2.38	180	6.7	86.1	129	172	258
30	12.7	1.57	180	4.5	57	85.5	114	171
40	12.7	1.57	180	3	37.97	56	75	113

**TABLE 3---Combs for 26cm wide unit**

SGC26 Combs for 26cm wide unit  # of wells	Tooth Depth mm	Spacing between teeth mm	Overall length of comb mm	Tooth width/ mm	Marker width/ mm	.75mm thickness volume per tooth microliters (ul)	1.0mm thickness volume per tooth microliters (ul)	1.5mm thickness volume per tooth microliters (ul)	2.0mm thickness volume per tooth microliters (ul)
25	10	2	247	7.1	1 @ 7.1	53.25	71	106.5	142
26	12	2	247	7	N/A	63	84	126	168
27	10	2	247	7	3 @ 5.6	52.5	70	105	140
28	10	2	247	7	4 @ 3.1	52.5	70	105	140
51	10	1	247	3.5	N/A	26.25	35	52.5	70
102	10	1	247	1.45	N/A	10.88	14.5	21.75	29

## SECTION 4

### Running Conditions

#### 4.1 Recommended Power



As a rule, optimal resolution of larger molecules is achieved during longer runs at lower voltages, whereas smaller molecules require shorter runs at higher voltages. Applied voltage gradients can therefore be anywhere in the range of 1-10 VDC/cm of gel. Using the standard buffer systems listed below, most runs will use 5 VDC/cm as a general rule.



The usual run time will vary for the voltage chosen but should range from 15 to 60 minutes. Nucleic acid migration is monitored by the progress of marker dyes. Constant power is not a necessity, but it produces uniform heat throughout the run, therefore minimizing band diffusion. Be sure the polarity is correct i.e. that the DNA is loaded near the cathode (black electrode) to run toward the anode (red terminal).

Agarose gels may be stored for several days at 4°C wrapped in plastic wrap. Seakem Agarose (FMC) is used (normally) for preparative and analytical gels. Other types of agarose can be used for special purposes.

#### 4.2 Recommended Buffer and Agarose Volumes

Cat. #	Gel Bed dimensions	Buffer (mls)	Agarose for 1cm thick slab (mls)
GCSGU-014T-02	14cm x 20cm	1500	290
GCSGU-020T-02	20cm x 20cm	1850	400
GCSGU-030T-02	20cm x 30cm	1950	600
GCSGU-040T-02	20cm x 40cm	2050	800
GCSGU-2614T-02	26cm x 14cm	2200	400
GCSGU-2626T-02	26cm x 26cm	2600	700
GCSGU-2640T-02	26cm x 40cm	3400	1100

#### 4.3 Recommended Buffers and Solutions\*

Type	Concentrated Stock/liter	Final Concentration
TAE (Tris-acetate)	50X - 242 gm Tris base 57.1ml glacial acetic acid 100 ml 0.5M EDTA (pH 8.0)	1X - 0.04M Tris-acetate 0.001M EDTA
TBE (Tris-borate)	5X - 54 gm Tris base 27.5 gm boric acid 20 ml 0.5M EDTA (pH 8.0)	0.5X - 0.045M Tris-borate 0.001M EDTA

##### 10X - Loading Buffer (DNA)\*

0.25% Bromophenol blue  
0.25% Xylene cyanol  
20% Ficoll Type 400  
0.1M EDTA, pH 8.0



##### Ethidium Bromide Staining

EtBr can be premixed with buffers and agarose for use during electrophoresis. Add to agarose only after temperature has fallen below 55°C. Gels can also be stained after electrophoresis in a soaking tray. Use EtBr at a final concentration of 0.1µg/ml from a 1mg/ml stock solution. Ethidium Bromide is a powerful mutagen. ALWAYS wear gloves, eye protection and protective clothing. Dispose of solutions in accordance with the safety regulations of your institution.

## 4.4 References

1. Hames, B.D., Rickwood, D. (ed.) (1990). *Gel Electrophoresis of Nucleic Acids. A Practical Approach*. 2<sup>nd</sup> edn. IRL Press, Oxford. Ch. 2.
2. Sambrook, J., Fritsch, E.F., Maniatis, T. (1989). *Molecular Cloning. A Laboratory Manual*. 2<sup>nd</sup> edn. Cold Spring Harbor Laboratory Press, Cold Spring Harbor, New York. Ch 6.
3. Ausubel, F.M., Brent, R., Kingston, R.E., Moore, D.D., Seidman, J.G., Smith, J.A., Struhl, K. (ed) (1993). *Current Protocols in Molecular Biology*. Vol. 1, Greene Publishing Associates, Inc. and John Wiley & Sons, Inc., Ch. 2.

## SECTION 5 Maintenance of Equipment

### 5.1 Care and Handling

The plastic components of the Submarine/Horizontal units are fabricated from acrylic and polycarbonate. Electrodes and connectors are made from pure platinum, stainless steel, and chrome plated brass. As with any laboratory instrument, adequate care ensures consistent and reliable performance.



After each use, rinse buffer chamber, gel tray and combs with de-ionized water. Wipe dry with a soft cloth or paper towel, or allow to air dry. Whenever necessary, all components may be washed gently with water and a non-abrasive detergent, and rinsed and dried as above. *Never* use abrasive cleaners, glass cleaning sprays or scouring pads to clean the components, as these will damage the unit and components.

Additional precautions:

- Do not autoclave or dry-heat sterilize the apparatus or components.
- Do not expose the apparatus or components to phenol, acetone, benzene, halogenated hydrocarbon solvents or alcohols.
- Avoid prolonged exposure of the apparatus or components to UV light.
- Do NOT treat with diethylpyrocarbonate (DEPC)-treated water for extended periods at 37°C. A brief rinse with DEPC-water is sufficient after a thorough wash.

### 5.2 Maintenance



The following inspection and maintenance procedures will help maintain the safety and reliable performance of the Submarine/Horizontal systems. Replacement parts can be ordered by calling 1-858-755-4959 or by contacting your local distributor.

- Banana plugs and power cords should be inspected regularly. If the banana plugs become loose or do not feel friction tight replace the plugs or power cords.
- Should power cord assemblies (connectors, wire or shrouds) show any signs of wear or damage (e.g. cracks, nicks, abrasions, or melted insulation), replace them immediately.
- The platinum wire is secured to the banana jack by compression between a stainless washer and the jack nut. The nut/washer interface should be tight and free of corrosion.

## SECTION 6

### Submarine/Horizontal Gel Kit and Accessories

Cat.#	Item
GCSGU-014T-02	<b>Submarine/Horizontal Gel Productivity Package-CE.</b> Gel bed dimensions are 14cm x 20cm. Includes 2 gel tray and 2 combs (please specify comb cat. #'s)
GCSGU-020T-02	<b>Submarine/Horizontal Gel Productivity Package-CE.</b> Gel bed dimensions are 20cm x 20cm. Includes 2 gel tray and 2 combs (please specify comb cat. #'s)
GCSGU-030T-02	<b>Submarine/Horizontal Gel Productivity Package.</b> Gel bed dimensions are 20cm x 30cm. Includes 2 gel tray and 2 combs (please specify comb cat. #'s)
GCSGU-040T-02	<b>Submarine/Horizontal Gel Productivity Package-CE.</b> Gel bed dimensions are 20cm x 40cm. Includes 2 gel tray and 2 combs (please specify comb cat. #'s)
GCSGU-2614T-02	<b>High-Throughput System Productivity Package-CE.</b> Gel bed dimensions are 26cm x 14cm. Includes 2 gel tray and 4 combs (please specify comb cat. #'s)
GCSGU-2626T-02	<b>High-Throughput System Productivity Package-CE.</b> Gel bed dimensions are 26cm x 26cm. Includes 2 gel tray and 4 combs (please specify comb cat. #'s)
GCSGU-2640T-02	<b>High-Throughput System Productivity Package-CE.</b> Gel bed dimensions are 26cm x 40cm. Includes 2 gel tray and 4 combs (please specify comb cat. #'s)

### Accessories:

#### COMBS (Available in Polycarbonate or Teflon-coated Aluminum\*\*)

##### FOR 14CM WIDE UNITS

Cat. #	Comb Dimensions
SGC14-1001	1mm x 1 well
SGC14-1003E	1mm x 3 equal wells
SGC14-1003M	1mm x 2 well + middle marker
SGC14-1005	1mm x 5 well
SGC14-1008	1mm x 8 well
SGC14-1010	1mm x 10 well
SGC14-1012	1mm x 12 well
SGC14-1013	1mm x 13 well*
SGC14-1016	1mm x 16 well
SGC14-1020	1mm x 20 well
SGC14-1026	1mm x 26 well
SGC14-1027	1mm x 27 well*
SGC14-1501	1.5mm x 1 well
SGC14-1503E	1.5mm x 3 equal wells
SGC14-1503M	1.5mm x 2 well + middle marker
SGC14-1505	1.5mm x 5 well
SGC14-1508	1.5mm x 8 well
SGC14-1510	1.5mm x 10 well
SGC14-1512	1.5mm x 12 well
SGC14-1513	1.5mm x 13 well*
SGC14-1516	1.5mm x 16 well
SGC14-1520	1.5mm x 20 well
SGC14-1526	1.5mm x 26 well
SGC14-1527	1.5mm x 27 well*
SGC14-2001	2mm x 1 well
SGC14-2003E	2mm x 3 equal wells
SGC14-2003M	2mm x 2 well + middle marker
SGC14-2005	2mm x 5 well
SGC14-2008	2mm x 8 well
SGC14-2010	2mm x 10 well
SGC14-2012	2mm x 12 well
SGC14-2013	2mm x 13 well*
SGC14-2016	2mm x 16 well
SGC14-2020	2mm x 20 well
SGC14-2026	2mm x 26 well
SGC14-2027	2mm x 27 well*
SGC14-3001	3mm x 1 well
SGC14-3003E	3mm x 3 equal wells
SGC14-3003M	3mm x 2 well + middle marker
SGC14-3005	3mm x 5 well
SGC14-3008	3mm x 8 well
SGC14-3010	3mm x 10 well
SGC14-3012	3mm x 12 well
SGC14-3013	3mm x 13 well*
SGC14-3016	3mm x 16 well
SGC14-3020	3mm x 20 well
SGC14-3026	3mm x 26 well
SGC14-3027	3mm x 27 well*

\*Designed for multi-channel pipettor loading.

\*\* To specify teflon-coated aluminum combs add "-TF" to end of cat. #.

##### FOR 20CM WIDE UNITS

Cat. #	Comb Dimensions
SGC20-1001	1mm x 1 well
SGC20-1003E	1mm x 3 equal wells
SGC20-1003M	1mm x 2 well + middle marker
SGC20-1005	1mm x 5 well
SGC20-1008	1mm x 8 well
SGC20-1012	1mm x 12 well
SGC20-1016	1mm x 16 well
SGC20-1020	1mm x 20 well*
SGC20-1030	1mm x 30 well
SGC20-1040	1mm x 40 well*
SGC20-1501	1.5mm x 1 well
SGC20-1503E	1.5mm x 3 equal wells
SGC20-1503M	1.5mm x 2 well + middle marker
SGC20-1505	1.5mm x 5 well
SGC20-1508	1.5mm x 8 well
SGC20-1512	1.5mm x 12 well
SGC20-1516	1.5mm x 16 well
SGC20-1520	1.5mm x 20 well*
SGC20-1530	1.5mm x 30 well
SGC20-1540	1.5mm x 40 well*
SGC20-2001	2mm x 1 well
SGC20-2003E	2mm x 3 equal wells
SGC20-2003M	2mm x 2 well + middle marker
SGC20-2005	2mm x 5 well
SGC20-2008	2mm x 8 well
SGC20-2012	2mm x 12 well
SGC20-2016	2mm x 16 well
SGC20-2020	2mm x 20 well*
SGC20-2030	2mm x 30 well
SGC20-2040	2mm x 40 well*
SGC20-3001	3mm x 1 well
SGC20-3003E	3mm x 3 equal wells
SGC20-3003M	3mm x 2 well + middle marker
SGC20-3005	3mm x 5 well
SGC20-3008	3mm x 8 well
SGC20-3012	3mm x 12 well
SGC20-3016	3mm x 16 well
SGC20-3020	3mm x 20 well*
SGC20-3030	3mm x 30 well
SGC20-3040	3mm x 40 well*

\*Designed for multi-channel pipettor loading.

\*\* To specify teflon-coated aluminum combs add "-TF" to end of cat. #.

## Accessories-continued:

### HIGH-THROUGHPUT SUBMARINE COMBS, with ADJUSTABLE BACKING FOR 26CM WIDE UNITS (Available in Polycarbonate or Teflon-coated Aluminum\*\*)

Cat. #	Comb dimensions
SGC26-7525-1MA	0.75mm x 25 well w/ marker
SGC26-1025-1MA	1.0mm x 25 well w/marker
SGC26-1525-1MA	1.5mm x 25 well w/ marker
SGC26-2025-1MA	2.0mm x 25 well w/marker
SGC26-7525-1MB	0.75mm x 25 well w/ marker
SGC26-1025-1MB	1.0mm x 25 well w/marker
SGC26-1525-1MB	1.5mm x 25 well w/ marker
SGC26-2025-1MB	2.0mm x 25 well w/marker
SGC26-7526	0.75mm x 26 well
SGC26-1026	1.0mm x 26 well
SGC26-1526	1.5mm x 26 well
SGC26-2026	2.0mm x 26 well
SGC26-7527-3M	0.75mm x 27 well w/ marker
SGC26-1027-3M	1.0mm x 27 well w/marker
SGC26-1527-3M	1.5mm x 27 well w/ marker
SGC26-2027-3M	2.0mm x 27 well w/marker

Cat.#	Comb Dimensions
SGC26-7528-4M	0.75mm x 28 well w/ marker
SGC26-1028-4M	1.0mm x 28 well w/marker
SGC26-1528-4M	1.5mm x 28 well w/ marker
SGC26-2028-4M	2.0mm x 28 well w/marker
SGC26-7551	0.75mm x 51 well
SGC26-1051	1.0mm x 51 well
SGC26-1551	1.5mm x 51 well
SGC26-2051	2.0mm x 51 well
SGC26-75102	0.75mm x 102 well
SGC26-10102	1.0mm x 102 well
SGC26-15102	1.5mm x 102 well
SGC26-20102	2.0mm x 102 well

\*\* To specify teflon-coated aluminum combs add "-TF" to end of cat.#

### HIGH-THROUGHPUT SUBMARINE GEL TRAY

Cat. #	Item
SGT-2614	Gel Tray for 26cm x 14cm, 5 slots. Pathlength of 2.5cm/slot
SGT-2626	Gel Tray for 26cm x 26cm, 8 slots. Pathlength of 2.5cm/slot
SGT-2640	Gel Tray for 26cm x 40cm, 8 slots. Pathlength of 4.3cm/slot

### GEL TRAYS (UV Transparent)

Cat. #	Item
SGT-014	Gel Tray for 14cm x 20cm, 6 slots. Pathlength of 2.6cm/slot
SGT-020	Gel Tray for 20cm x 20cm, 6 slots. Pathlength of 2.6cm/slot
SGT-030	Gel Tray for 20cm x 30cm, 9 slots. Pathlength of 2.7cm/slot
SGT-040	Gel Tray for 20cm x 40cm, 12 slots. Pathlength of 2.7cm/slot

### GEL SCOOP

Cat.#	Scoop Dimensions
GS-1400	14cm x 20cm
GS-2000	20cm x 20cm
GS-3000	20cm x 30cm
GS-4000	20cm x 40cm

### GEL TRAY DIVIDER BAR

Cat.#	Item
GTD-1400	Divider Bar for 14cm wide units
GTD-2000	Divider Bar for 20cm wide units

### GEL COMB BRIDGE

Cat.#	Item
GCB-1400	Bridge for 14cm wide units
GCB-2000	Bridge for 20cm wide units

### Continuously Adjustable Gel Caster

Cat.#	Item
AGCT-16520	Caster max(w) 16cm min(l)8 max(l) 20cm
AGCT-21826	Caster max(w) 21cm min(l)8 max(l) 26cm
AGCT-27940	Caster max(w) 27cm min(l)9 max(l) 40cm

### HORIZONTAL GEL CASTERS

Cat.#	Item
GCT14-201	Gel Casting Tray for 14cm (w) x 20cm (l), single place
GCT14-202	Gel Casting Tray for 14cm (w) x 20cm (l), two place
GCT20-201	Gel Casting Tray for 20cm (w) x 20cm (l), single place
GCT20-202	Gel Casting Tray for 20cm (w) x 20cm (l), two place
GCT20-301	Gel Casting Tray for 20cm (w) x 30cm (l), single place
GCT20-302	Gel Casting Tray for 20cm (w) x 30cm (l), two place
GCT20-401	Gel Casting Tray for 20cm (w) x 40cm (l), single place
GCT20-402	Gel Casting Tray for 20cm (w) x 40cm (l), two place
GCT26-141	Gel Casting Tray for 26cm (w) x 14cm (l), single place
GCT26-142	Gel Casting Tray for 26cm (w) x 14cm (l), two place
GCT26-261	Gel Casting Tray for 26cm (w) x 26cm (l), single place
GCT26-262	Gel Casting Tray for 26cm (w) x 26cm (l), two place
GCT26-401	Gel Casting Tray for 26cm (w) x 40cm (l), single place
GCT26-402	Gel Casting Tray for 26cm (w) x 40cm (l), two place

### POWER SUPPLIES

Cat. #	Item
EPS-300-X	Mini Power Supply, with timer, CV or CC, 10-300V, current range:4-500mA, 90 watts
EPS-200-X	Mini Power Supply, with timer, CV or CC, 5-200V, current range:4-2000mA, 200 watts

# CONTACT US



**Telephone:**  
Local or International  
858-755-4959  
Toll Free: 858-755-0733



**Fax:** 858-755-0733



Check out our new and improved online ordering!

[www.cbsscientific.com](http://www.cbsscientific.com)



**E-mail address:**  
[sales@cbssci.com](mailto:sales@cbssci.com)



**Mailing address:**  
C.B.S. Scientific Company  
P.O. Box 856  
Del Mar, CA 92014



**Shipping address:**  
C.B.S. Scientific Company  
10805 Vista Sorrento Pkwy  
Suite 100  
San Diego, CA 92121



**Credit Card Options:**  
Visa/Mastercard  
Discover/American Express